

Nova **brik**

SELF-VENTILATED MORTARLESS BRICK SIDING

Installation *Guide*



Components and Accessories

The items shown on this page and on the inside of the back cover, are the components and accessories manufactured or distributed by **Cindercrete Products, Ltd.** Refer to this section when you see "Check availability" in this booklet. Some retailers may not carry all the components.

Novabrik

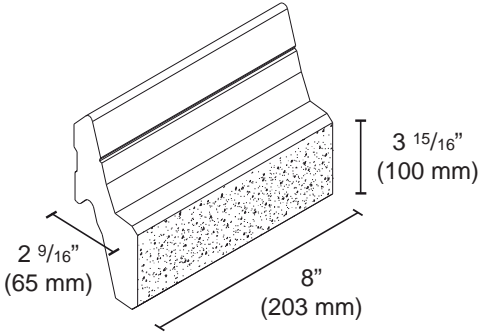

- Coverage: 4.6 bricks/ft²
(50.0 bricks/m²)
- Weight: 6.1 lbs/brick
(2.8 kg/brick)
28.1 lbs/ft²
(140.0 kg/m²)
- Quantity per pallet: 576

90° Exterior Corner

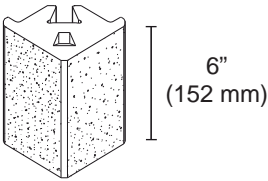

- Weight: 4.8 lbs (2.2 kg)
- Quantity per pallet: 240

90° Interior Corner

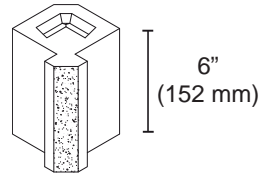

- Weight: 6.1 lbs (2.8 kg)
- Quantity per pallet: 80

45° Exterior Corner

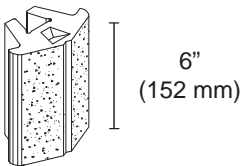

- Weight: 3.2 lbs (1.5 kg)
- Quantity per pallet: 108

45° Interior Corner

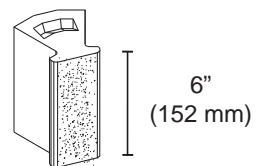

- Weight: 4.2 lbs (1.9 kg)
- Quantity per pallet: 96

Components and Accessories

Window Sill

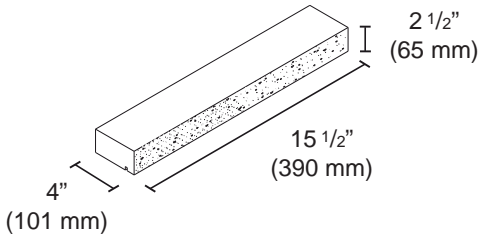

- Weight: 12.0 lbs (5.4 kg)
- Quantity per pallet: 112

Wainscot Cap

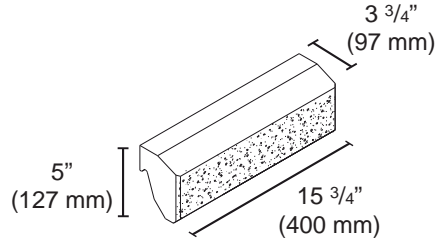

- Weight: 17.1 lbs (7.8 kg)
- Units per pallet: 120

90° Corner Strip



length: 4 ft
(1219 mm)

- Weight: 2.2 lbs (1.0 kg)
- Quantity per box: 20

SV-Starter Strip

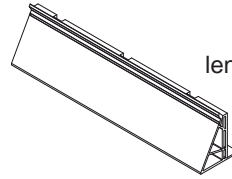

length: 8 ft
(2438 mm)

- Weight: 4.4 lbs (2.0 kg)
- Units per bag: 10

45° Corner Strip

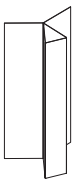

length: 4 ft
(1219 mm)

- Weight: 2.2 lbs (1.0 kg)
- Units per box: 20

Certification & Evaluation Reports

- CCMC Evaluation Report 12833-R

Table of Contents

Before You Begin	
Introduction	2
Use and Restrictions.....	2
Material Take-off	3
Tools and Equipment	5
Insulation, Openings and Housewrap.....	6
Preparation	
Wall Preparation	7
Header Reinforcement Above Openings	8
Gable	9
Overhang Section.....	10
Novabrik installation	
90° Exterior Corner	11
45° Exterior Corner	13
90°/ 45° Interior Corner.....	15
90° Interior Corner - Overlapping Brick Method	15
Installing the SV-Starter and Furring Strips	16
Brick Coursing	17
Installing the Novabrik	18
Combining Novabrik with Existing Siding	19
Window Sill Installation	20
Installation Above Openings	21
Window Trim.....	22
Aluminum or Steel Flashing Around Openings.....	23
Details	
Soldier Course Installation.....	24
Installation on Rounded Openings.....	26
Soffit Details.....	28
Wainscot Architectural Detail	29
Novabrik on various types of structures	
Novabrik on Concrete Blocks	30
Novabrik on ICF.....	31
Novabrik on Structural Insulated Panels (SIPs).....	32
Novabrik on Post Frame Structures.....	33
Questions & Tips	
Frequently Asked Questions.....	34
Tips	35

Introduction

This booklet describes the steps required to install Novabrik on a standard wood frame construction. Its purpose is to provide basic information that will simplify the installation process while assuring successful results.

This guide does not claim to cover all situations that may occur. If your project involves a different building frame, such as **steel studs, SIPs, concrete blocks** or **insulated concrete forms**, among others, please consult your dealer or Novabrik manufacturer for installation details. You may also visit our web site at www.novabrik.com for further information.

Building codes and regulations vary throughout the country. Be sure to check with your local code official for specific framing requirements in your area. **For further information you can refer to the Evaluation Reports on the inside cover of this guide or visit the Novabrik web site.**

The information and product applications illustrated in this manual have been carefully compiled by Novabrik International Inc. and its Licensed Producers, and to the best of our knowledge it accurately represents the use of Novabrik. Final determination of the suitability of any information or material for the contemplated use and its manner of use is the sole responsibility of the user.

Use and Restrictions

Novabrik can be used on new constructions and for remodeling. Novabrik hangs on the wall, therefore **no brick ledge is required**.

For buildings not built on structural footings, check with a local building professional to make sure your foundation will adequately handle the added weight.

Height of veneer

Novabrik is limited to a height of 30 ft. (9144mm) at top of plate. Heights may be increased when specified by a structural engineer and approved by building officials.

Floater

When a section of a wall wraps over the top of the roof, we call it a “floater”. This area will need extra support prior to the installation of Novabrik.

Check with a professional builder or engineer to determine the structural requirements for the added weight.

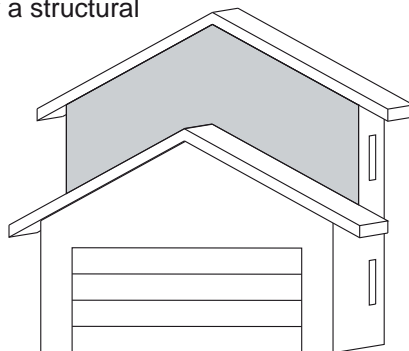

Material Take-off

This planning guide will help you determine the amount of Novabrik and its accessories required to complete your project. You may also refer to our estimating sheet under the “Get A Quote” section on the Novabrik web site or on the corporate CD-rom.

Step 1

Make sketches of the home showing all sides.

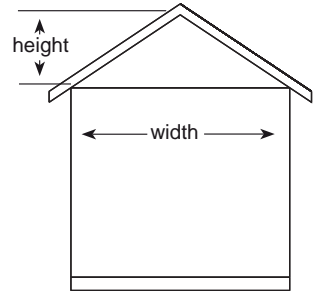
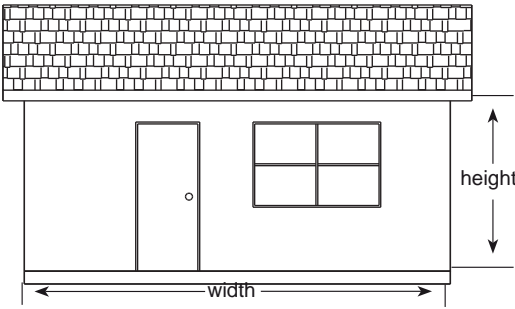

Step 2

Measure the height of each side (excluding gables) and multiply by the width to obtain the surface area.

For gables, measure the height at center, add 1' (300mm) to allow for waste, and multiply by 1/2 of the width to obtain the surface area.

Add the areas together.

Step 3

Measure all windows, doors and any other area that will not be covered with Novabrik. Multiply the width by the height of each area, then add the results.

Step 4

Take the result of Step 2 and subtract it from the result obtained in Step 3. Add 2% for waste. This will give you your Total Square Footage.

Multiply the Total Square Footage by the coverage factor (refer to the inside front cover of the Installation Guide) to obtain the required number of Novabrik.

Material Take-off

Starter Strip

Add the length of each wall plus the width of all doors and windows to calculate the total length of starter strip needed (refer to the inside cover of this guide).

Door and Window Trim (check availability)

Calculate the sides and top of all windows to obtain the required length of the window trim, add them together. Repeat this step with the doors.

Furring Strip 1" x 3" (19mm x 64mm) or 1" x 4" (19mm x 89mm)

Make sure you have enough furring strips to overlay all of the framing studs, and enough to wrap around all windows and doors.

Window Sill / Wainscot Cap

Measure and record the width of each window separately to determine the total length of window sill needed. Order enough sills so that you can use larger pieces under each window, with as few joints as possible.

Construction Adhesive

Use PL® Premium polyurethane construction adhesive or equivalent.

Corner Block

Measure the height of each wall at the corner (in feet) and multiply by the coverage factor (refer to the inside cover of this guide) to find the number of corner blocks needed. Add 10% for waste.

Housewrap

Calculate the area for all of the walls add them together to obtain the amount of housewrap needed.

Corrosion-resistant Screws

Calculate 1.5 screws per sq. ft.. This will give you enough screws to attach the furring strips and the Novabrik.

For coastal areas (less than 5 miles (8 km) from the ocean) or near any corrosive environment (e.i. highways) use stainless steel fasteners.

When attaching the veneer's wood furring strips to preservative-treated wood, fasteners should be of hot dipped zinc coated galvanized steel.

Tools and Equipment

A proper set of tools will get the job done right. Safety is the number one item on any construction project. Use protective eye wear when cutting brick.

Tool List

- ½" (13mm) or 9/16" (14mm) hammer drill (not a rotary SDS hammer drill)
- 3/16" (5mm) and 7/32" (6mm) masonry drill bits designed for a hammer drill
- cordless drill
- drivers for drill to match screws
- chop saw with diamond blade or masonry saw
- level
- rubber hammer
- hand held brush
- measuring tape
- string line for leveling
- utility knife
- skill saw (for wood strips)
- caulking gun
- scaffolding
- hammer
- gloves
- safety glasses
- dust mask
- earplugs

Note on cutting Novabrik

Cutting brick is often a key part of installation. You can use either a wet saw or a dry saw with diamond blades.

Although a dry saw will be easier to move around. A wet saw will reduce dust while cutting. Thoroughly rinse with clean water to remove any cement paste left over to avoid staining when the brick dries up.

Take all necessary precautions to protect yourself from dust. Use safety glasses and a dust mask.



Chop saw with diamond blade

Insulation, Openings and Housewrap

Before going into details regarding the preparation work and installation of Novabrik, here are a few important notes on insulation, flashing and housewrap for your home.

Insulation

If you're replacing an old siding, this is a perfect time to insulate your house from the exterior. Use rigid insulation, extruded polystyrene foam type, and fasten the furring strips through the insulation into the studs using longer screws.

Thermal Control

Walls retrofitted with thermal insulation must meet the requirements for heat transfer, air leakage and condensation control of your local Building Code.

Openings

Seal the flanges around the window with a self-adhesive waterproof membrane. Start at the bottom (1), follow the sides (2) and, finish with the top (3). Make sure to overlap the waterproof membrane properly. Ensure that adhesive flashing is adequately bonded to the vapor/air barrier and in full contact with the perimeter surface opening.

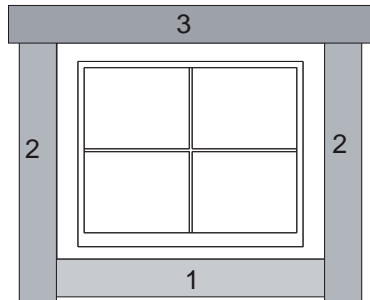

Housewrap

When installing a housewrap, make sure it is properly layered where necessary. Overlap layers at least 6" (150mm) and tape the seams with a tape from an approved manufacturer.

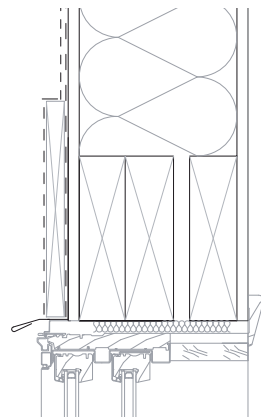

Note: For clarity reasons, housewrap and flexible flashing are not shown on all drawings in this booklet.

Wall Preparation

Remove the existing siding and make sure the wall is sound and not degraded due to wet or dry rot. If this is the case, reconstruct with new substrate materials before installing the new Novabrik siding. Have a qualified electrician extend the exterior outlets and light fixtures, and move the electric meter. Finally, have a qualified plumber extend the hose bib and remove downspouts if necessary.

- **Studs**

2" x 4" (38mm x 89mm) or
2" x 6" (38mm x 140mm)

- **Sheathing**

(as specified by the Architect)

- **Housewrap**

Make sure the housewrap covers the sheathing. Seal all joints with a tape of an approved manufacturer.

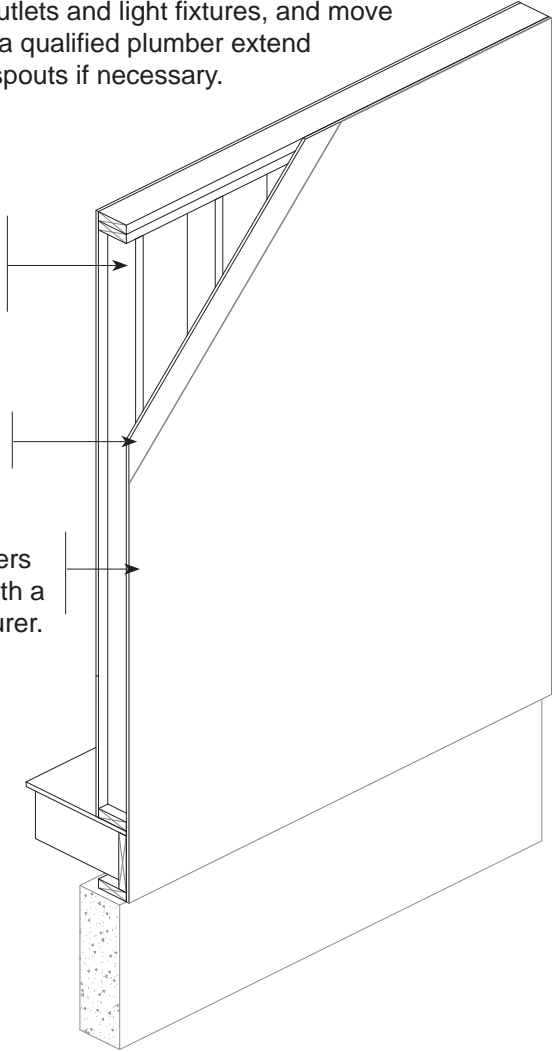

Before you start installing the furring strips, indicate the stud location of your building on to the housewrap.

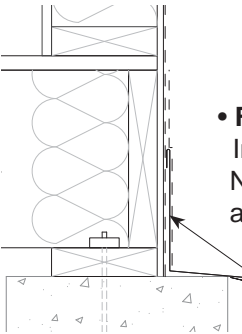

- **Flashing**

In cases where the foundation ledge exceeds the Novabrik veneer, it is required to install a flashing at the base of the wall.

Have the housewrap overlap the flashing by at least 6" (150mm)

Header Reinforcement Above Openings

Doors and windows need extra framing to support the brick above. In the case of new construction, your consultant can ensure the lintel is designed so that no extra reinforcement is necessary. Remember that Novabrik weights about 27 lb/sq. ft. (132 kg/sq. m).

Header reinforcement is required for remodelling work since the lintel has not been previously designed to support the extra weight of Novabrik. Use the header chart to size each window and door header. Make sure the header extends 6" (150mm) past the opening on each side.

Fasten the plywood header to the studs and existing framing header with 2 rows of #10 screws at 10" (250mm) c/c. Make sure to cover the reinforcing header with flashing or a piece of housewrap, overlaped underneath the housewrap above. If you want to install a soldier course above the opening, you need a plywood reinforcing header 15" (380mm) high.

Header Chart

Required Height of Plywood Lintel (in.)

No. Rows of Novabrik Supported	Width of Opening (ft.)							
	1	2	3	4	5	6	7	8
1	7"	7"	7"	7"	7"	7"	8"	8"
2	7"	7"	7"	7"	8"	11"	11"	14"
3	7"	7"	7"	7"	8"	11"	11"	14"
4	7"	7"	7"	7"	11"	11"	14"	14"
5	7"	7"	7"	8"	11"	14"	14"	16"
6	7"	7"	7"	8"	11"	14"	14"	16"
7	7"	7"	7"	8"	11"	14"	16"	16"
8	7"	7"	7"	11"	14"	14"	16"	19"
9	7"	7"	8"	11"	14"	16"	16"	19"
10	7"	7"	8"	11"	14"	16"	19"	22"
11	7"	7"	8"	11"	14"	16"	19"	22"
15	7"	7"	11"	14"	16"	19"	22"	24"
19	7"	7"	11"	14"	19"	22"	24"	*
23	7"	8"	14"	16"	19"	24"	*	*
26	7"	8"	14"	16"	22"	24"	*	*
30	7"	11"	14"	19"	22"	*	*	*
34	7"	11"	14"	19"	24"	*	*	*
38	7"	11"	16"	19"	24"	*	*	*
41	7"	11"	16"	22"	*	*	*	*
45	7"	14"	19"	24"	*	*	*	*

* For such cases please consult an engineer

Header Reinforcement Above Openings

Example:

Width of opening ("a"):

6' (1.8m)

Rows of bricks above:

11 (3 rows per 1' (305mm))

From the header chart:

height of header: 16" (400mm)

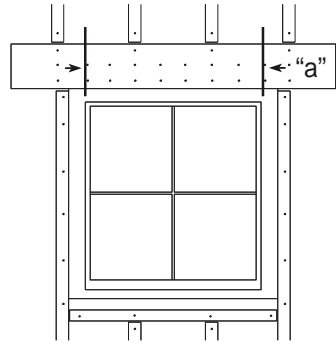

To install Novabrik over large openings or 'wide spans', extra structural review is essential. In some cases, steel may be required for extra reinforcement. In those situations use a steel plate, cut to the appropriate length, pre-drill and attach with screws. Always consult a structural engineer when designing the reinforcement.

Gable Preparation

We refer to the triangular shaped part of a wall as a "roof gable". This section of the wall extends up and into the roof line, and needs extra support before adding Novabrik.

On smaller gables, less than 12' (3.7m) wide from corner to corner, no extra support is needed.

On larger gables, if there is no plywood or OSB on the existing framing, remove the existing sheathing and replace with plywood of the same thickness. Cover with housewrap and install furring strips over the framing.

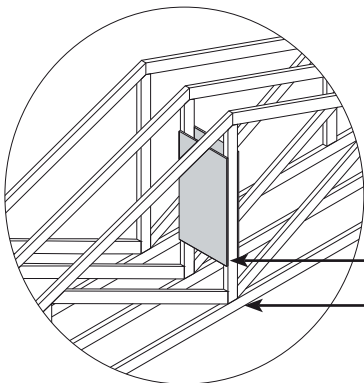
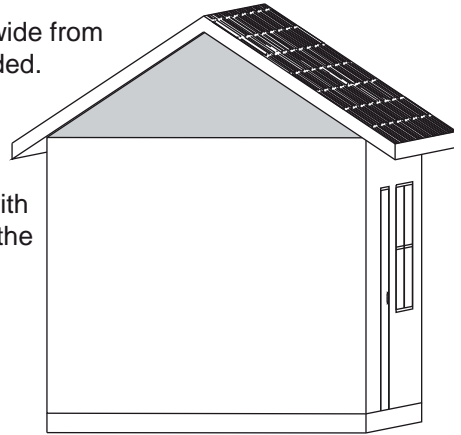

Bracing

End truss

On large gables, add bracing between the first and second truss in the attic space to prevent wall from racking.

Overhang Section

Limit Novabrik installation to one story on overhanging sections and extending maximum 16" (400mm) with floor joist spacing 16" (400mm) on center maximum.

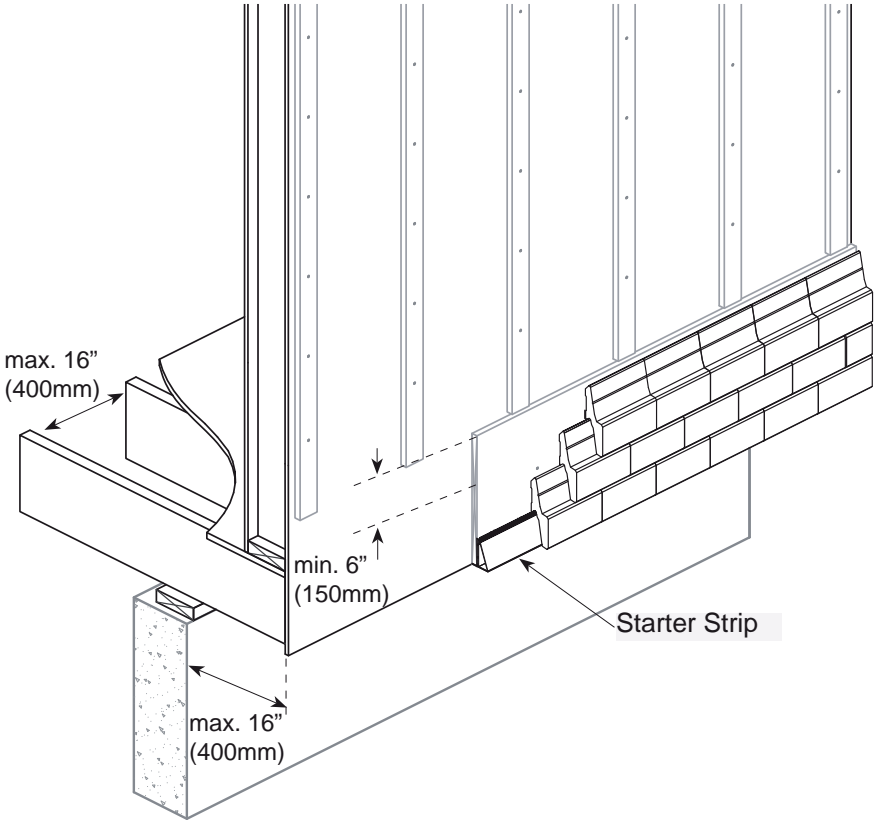

- Install $\frac{3}{4}$ " (19mm) plywood as baseboard, extend plywood minimum 6" (150mm) above floor.
- Make sure to fasten top of baseboard to both the sill plate and studs.
- Fasten each Novabrik on the first course with two screws.
- Fasten each Novabrik at top of baseboard with two screws.
- Continue installation in the usual manner.

Note: If the overhang is longer than 16" (400mm) or if the wall is higher than one story, consult a structural engineer.

90° Exterior Corner

Step 1

Pre-drill a hole at a 30° downward angle in the notch of each corner block before installation.

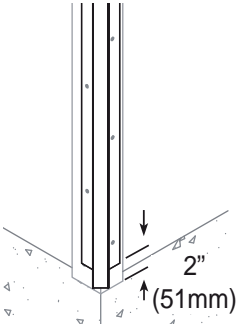
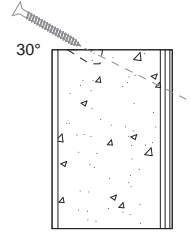

Step 2

- Install 1" x 4" (19mm x 89mm) furring strips over the corner of the house.
- Use 1" x 6" (19mm x 140mm) furring strips if installing over rigid insulation.
- Plumb corners and fasten corner strip.
- Fasten corner strip with # 10 corrosion resistant screws at 10" (250mm) c/c, in a staggering pattern.

Step 3

- Slide down the first corner block and align with the bottom of the first course of Novabrik.
- Holding the corner block firmly in place, screw it into the steel corner strip with one 2½" (64mm) #10 corrosion-resistant screw. Make sure the block does not slip.
- Apply a small amount of construction adhesive in between each block to lock them together.

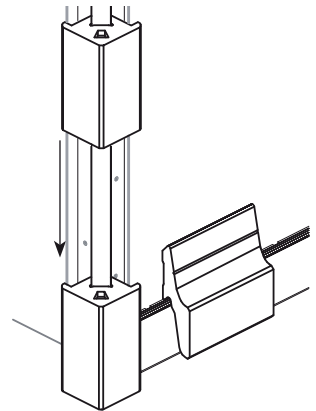
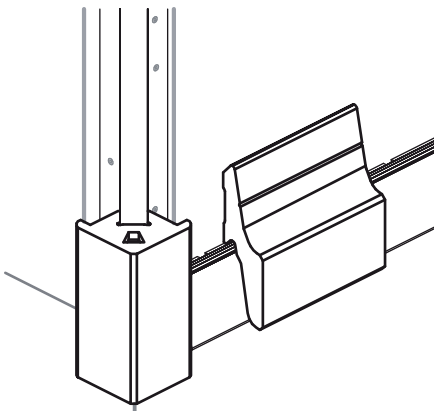
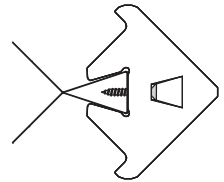

90° Exterior Corner

Step 4

- Continue to install blocks the same way up to the end of the first corner strip.
- Insert one more block onto the corner strip.
- Slide down second steel corner strip into the last block.
- Align with bottom strip and fasten to the wall.

Step 5

- Continue up the wall to the end of the last full length steel corner strip.
- Insert one more block into the corner strip.

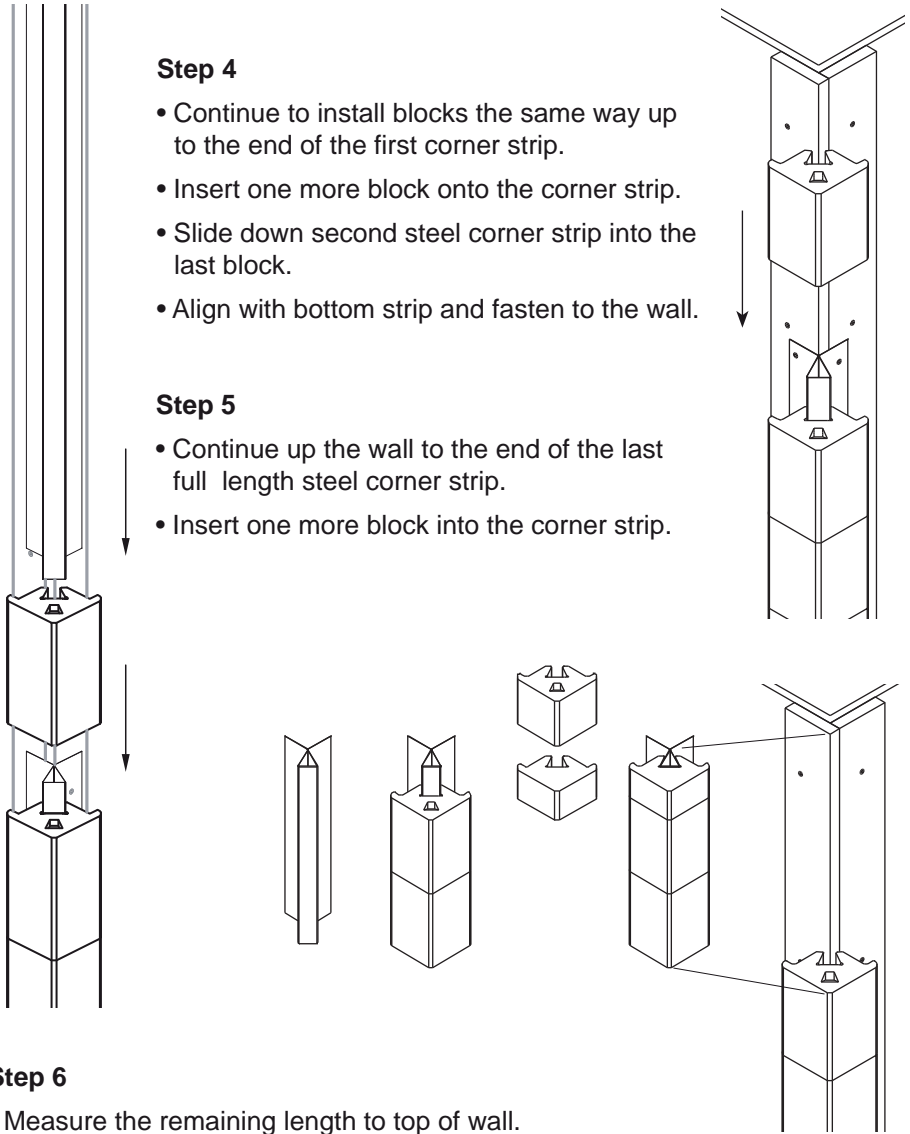

Step 6

- Measure the remaining length to top of wall.
- Cut the corner strip accordingly (this step is easier if you make the last strip 18" (450mm) long or less, repeat step 4 with the shorter corner strip to approach the top of the wall).
- Fasten the required number of blocks onto the strip, cut the last block to fit and attach with adhesive.
- Fasten the steel corner strip assembly to the wall.

45° Exterior Corner

Use 45° corner blocks for turrets, bay windows and for any other corner with an angle between 15° and 75°.

This 45° exterior corner block is installed exactly as the 90° exterior corner block (see 90° exterior corner section). Use the corner strip specifically designed for the given Novabrik corner.

Step 1

- Install 1" x 4" (19mm x 89mm) furring strips over the corner of the house.
- Use 1" x 6" (19mm x 140mm) furring strips if installing over rigid insulation.
- Bend the corner strip to match the angle of the corner by pushing it against a flat surface and twisting it with your hands.

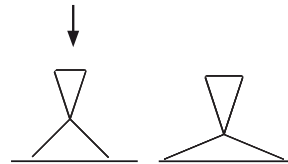
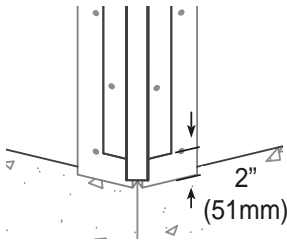

- Plumb corners and fasten corner strip.
- Fasten first corner strip with #10 corrosion-resistant screws at 10" (250mm) o/c in a staggering pattern.

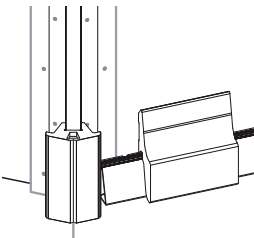

Step 2

- Slide down the first corner block and align it with the bottom of the first course of Novabrik.
- Holding the corner block firmly in place, screw it into the steel corner strip with one 2½" (64mm) #10 corrosion-resistant screw. Make sure the block does not slip.
- Apply a small amount of construction adhesive in between each block to lock them together.

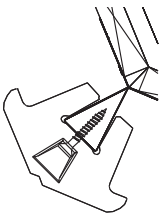

45° Exterior Corner

Step 3

- Install blocks the same way up to the end of the first steel corner strip.
- Insert one more block onto the corner strip.
- Slide down second steel corner strip into the last block.

Step 4

- Align the second corner strip with bottom one and fasten it to the wall.
- Continue up the wall to the end of the last full length steel corner strip.
- Insert one more block into protruding strip.

Step 5

- Measure the remaining length to top of wall.
- Cut the corner strip to length (this step is easier if you make the last strip 18" (450mm) long or less, repeat step 4 with a shorter corner strip to approach to the top of the wall).
- Fasten the required number of blocks to the strip, cut the last block to fit and attach with adhesive.
- Fasten the corner strip assembly to the wall.

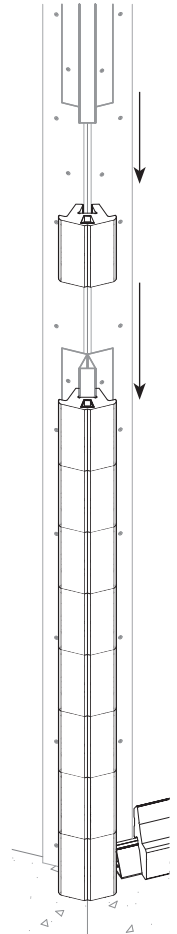
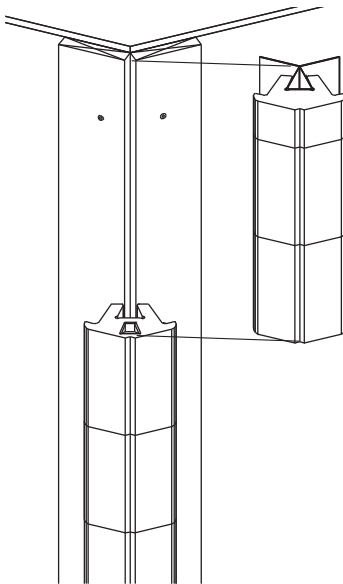

90° Interior Corner / 45° Interior Corner

Interior corners are built using an interior corner block or by overlapping one brick facing over the other.

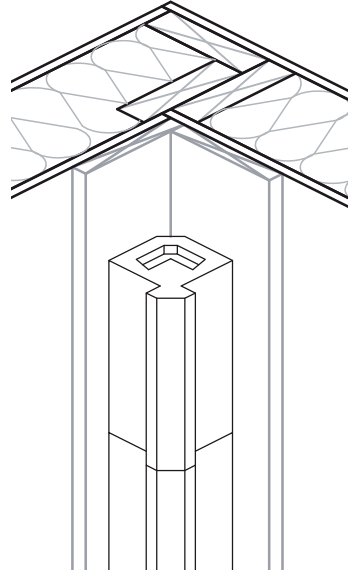
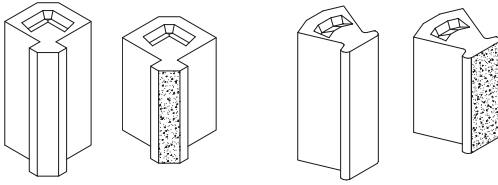

- Install 1" x 6" (19mm x140mm) boards over the corner of the house. Correct out of plumb or uneven corners at this point.
- Pre-drill a hole at a 30° downward angle in each corner block. Align the holes towards the studs of the wall.
- Use a 4" (100mm) long corrosion-resistant screw to fasten each block. Apply construction adhesive between blocks.

90° Interior Corner - Overlapping Bricks Method

- At each interior corner fasten 1" x 6" (19mm x 140mm) boards to the structural frame and cover with a waterproof membrane.
- Use a waterproof membrane between the furring strips and the wall to protect sheathing against moisture.
- Install Novabrik on one wall all the way up to the corner.
- Cut and adjust flanking pieces to achieve a consistent 3/8" (10mm) gap.
- Once both walls are finished, insert a foam backer rod (have the foam backer rod compressed by 50%) and apply a bead of sealant down the entire joint between the bricks.

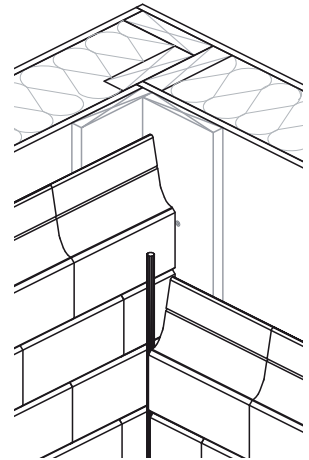

Plan to make the bead of sealant the least apparent. For example, install the brick on the wall parallel to the street all the way to the corner.

Installing the SV-Starter and Furring Strips

To install the starter strip, follow these steps:

- Measure and mark each corner where you want the first row of Novabrik to start. We usually mark each corner at 1/2" (13mm) above the foundation.
- Hold the string straight and tight at both ends and snap the line on the house wrap.
- Line up the furring strips over the framing studs and above the chalk line. Attach with #10 corrosion resistant screws at 10" (250mm) c/c. The screws must penetrate at least 1 1/4" (32mm) into the studs.

NOTE: Do not screw the furring strips at elevation 0", they will be screwed into studs when anchoring the starter strip.

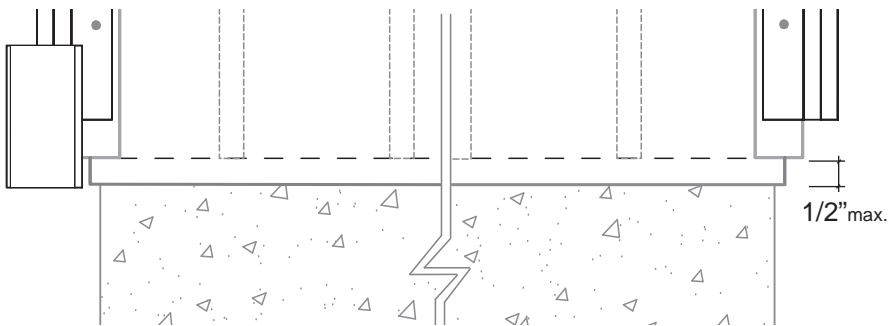

- Position the starter strip's flange underneath the furring strips and assure a perfect level before you fasten the strip at every furring strip. Attach with #10 corrosion resistant screws. The screws must penetrate at least 1 1/4" (32mm) into the perimeter joists or into the studs.

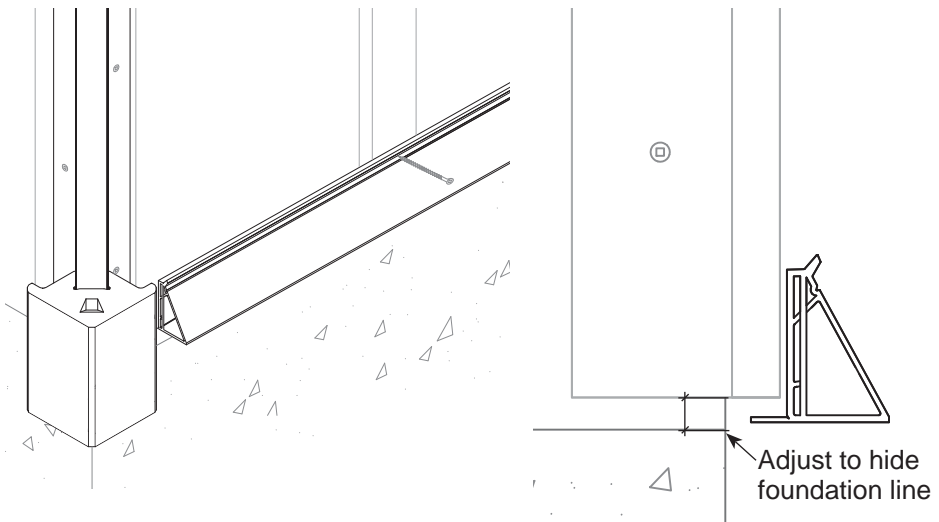

Brick Coursing

The aesthetic look is a very important aspect of the project. Locate the openings on the wall and the bricks so to arrange the pattern to fit around your windows or doors with the least amount of small bricks needed.

- Place a row of Novabrik on the starter strip.
- Check the alternating courses by placing two Novabrik on the second row as shown on the illustration.
- Sight down from the window corners to see how the seams line up.
- Adjust the first row in a way that gets the best fit around the windows or doors.

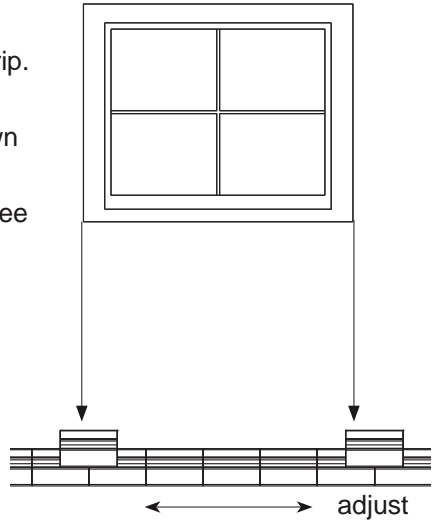

RIGHT

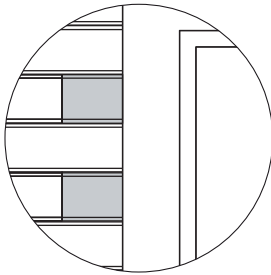

WRONG

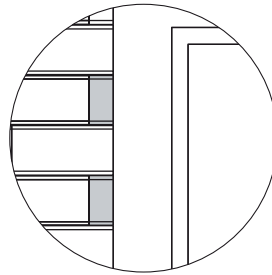

You can make slight adjustments along the sides of openings if needed to improve the final look

Note: Novabrik has 4" (100mm) of nominal height. You might lose approximately 5/8" (16mm) every 10 rows.

Installing the Novabrik

With all the prep work completed, you are ready to install Novabrik.

- Install the Novabrik on the Starter Strip*. At every furring strip, hold down the face of the brick and drill holes at a downward angle (around 30°).
- Hold the brick flat on the wall and anchor it with a # 10 x 2 ½" (64mm) screw at a slight downward angle until the head touches the brick. Do not over-tighten.
- Be sure to mix Novabrik from different pallets as you stack and install. This will blend the Novabrik together.
- Check the leveling at every fourth course before fastening and make adjustments if necessary. A long level or straight edge can help.
- Use your rubber mallet and wood straight edge to tap the bricks in place and brush down with a small broom to remove dirt and dust.

**Note: See the *Materials take off* section for screw specifications
Refer to Starter & Furring Strip Installation section.**

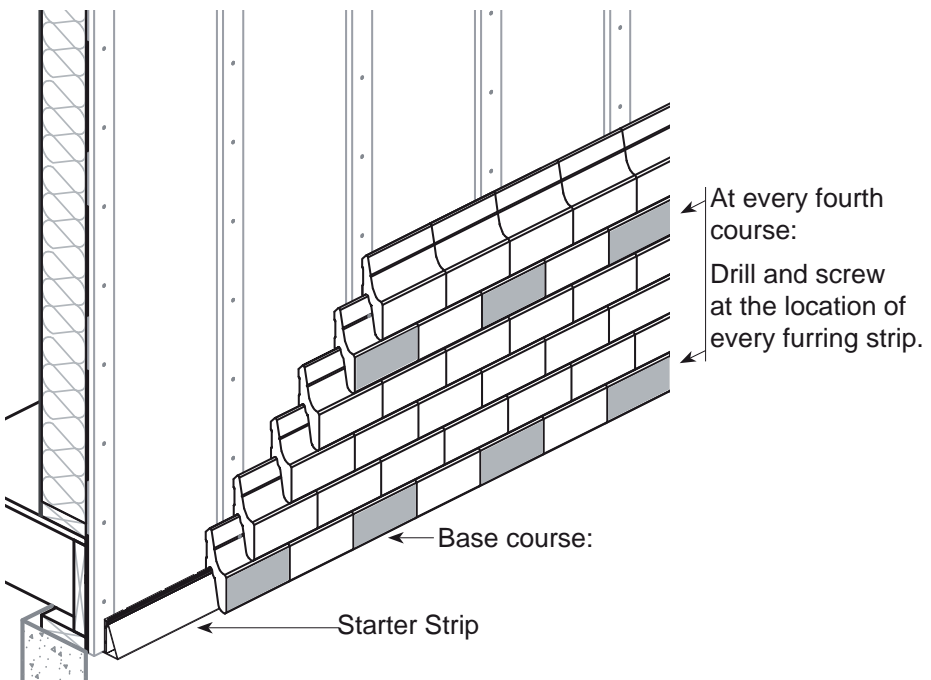

Note: Use #10 corrosion-resistant screws to fasten furring strips to the studs. Make sure the screws penetrate at least 1 ¼" (32mm) into the studs.

Combining Novabrik with an Existing Siding

There are two ways we recommend when adjoining an existing siding with your new Novabrik veneer and with the Fast Track corner blocks.

Method 1

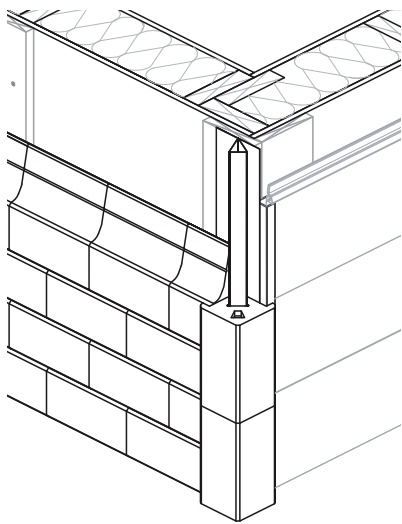

- Bend the corner strip by pushing it against a flat surface and twisting it with your hands.

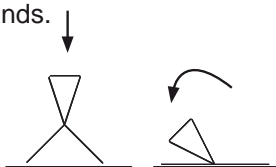

- Bring the corner block towards the middle of the facade, leaving only the depth needed for the existing siding.

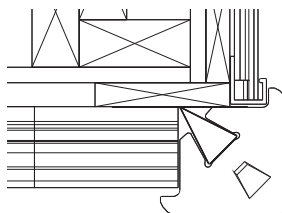

1" x 6"
(19mm x 140mm)
instead of 1" x 4"
(38mm x 89mm)

Method 2

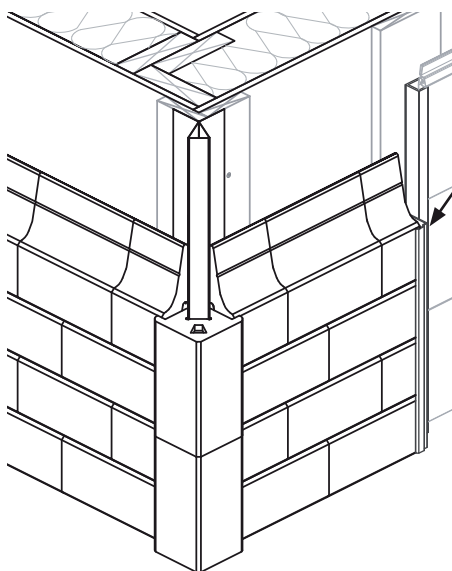

You can use window trims to conceal the edge of the brick

- Install the corner block in the usual way.
- Cut the siding and install Novabrik up to the first stud.
- Install a new J channel and apply caulking at the joint.

Window Sill Installation

Window sills require a bit of cutting and fitting. **Install sill at a downward angle to provide for water run off from the house.**

- The space between the window frame and the horizontal furring strip has to be at least the thickness of your sill plus 1/8" (3mm) to insert the window sill.
- Cut the top of the bricks under the window if needed.
- Apply a large bead of adhesive along the top of the bricks and the horizontal furring.
- Insert sill blocks under window frame and set into adhesive.
- Insert a small filler piece and attach with adhesive.
- Caulk between bottom of window and top of sill.

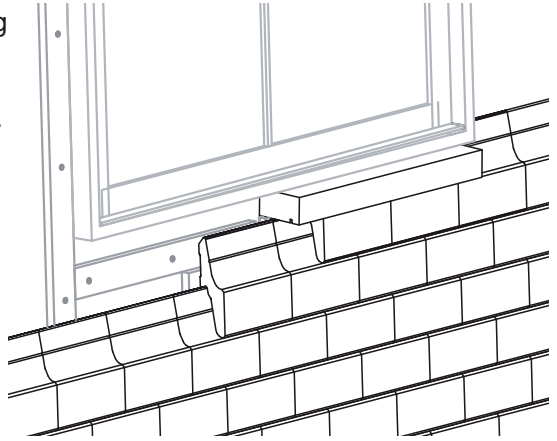

Cut filler pieces to fit under the window sill and secure with adhesive.

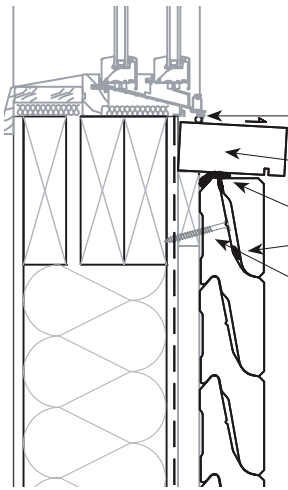
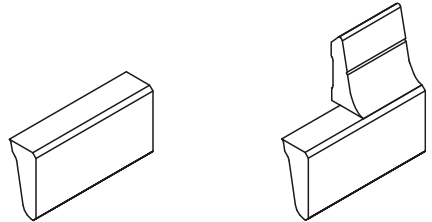

caulk between window frame and sill

#10 x 4" (100mm) corrosion resistant screw, either on the sides or underneath the sill.

secure sill and filler piece with construction adhesive.

fasten each Novabrik under window sill with 2 screws, cut the top of the bricks if necessary

Note: If necessary cut sills to equal length for a better harmonized look under the window.

Installation Above Openings

This page shows the installation of a horizontal course above openings. Install a 3/4" (19mm) thick plywood reinforcement header sized according to the header reinforcement section. Cover this header with a housewrap or a waterproof membrane.

A continuous housewrap or a waterproof membrane tucked under housewrap

Plywood reinforcement header

Starter Strip

Aluminum or steel flashing

Window frame

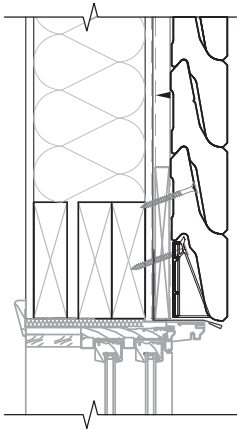
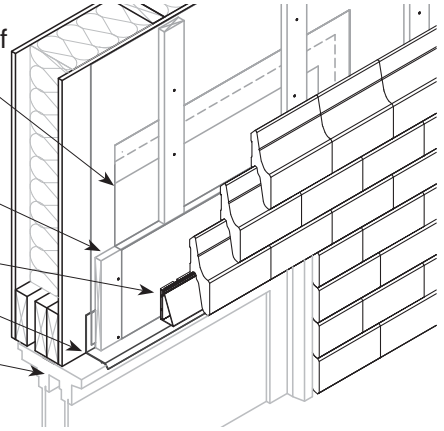

- Install aluminum or steel flashing above opening.
- Cover plywood and metallic flashing with a waterproof membrane or housewrap.
- Locate the "V" mark on the starter strip flange, cut with a utility knife and snap it off.
- Install and level your starter strip above the opening.
- Locate the screw point location on the starter strip and fasten with # 10 x 2 1/2" (64mm) corrosion resistant screws at every 16" (400mm) c/c.
- Install and screw each Novabrik on the Starter Strip with a # 10 x 2 1/2" (64mm) corrosion resistant screw at every 16" (400mm) c/c.

If you do not have a full brick above the opening, cutting will be required (see detail beside). Cut the starter strip as well so you have a level line to install the bricks. Installing a soldier course is a very attractive alternative to horizontal cuts (see soldier course installation section).

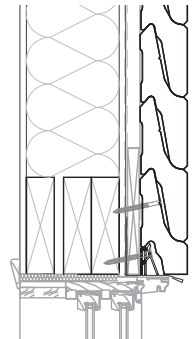

Window Trim (check for availability.)

Window trim is used to extend the window frame out. It can be installed in two ways. Covering the edge of the bricks or giving Novabrik an edge to butt up to.

Note that the furring strip and Novabrik will add 3 1/4" (83mm) to the face of your wall.

- Cut the trim pieces to the proper length of the sides and top of windows (make sure the top piece overlaps the sides), extend the side trim down past the top of the sill and butt the sill to the trim.
- Install the trim over the furring strips if you want the trim to cover the bricks (1), or install the header and furring strips over the back of the trim if you want the bricks to butt up to it (2).

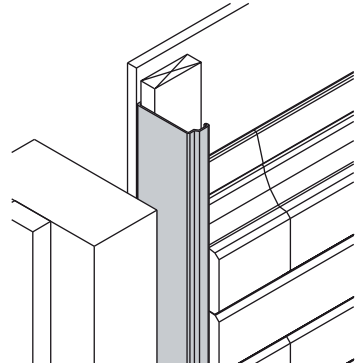
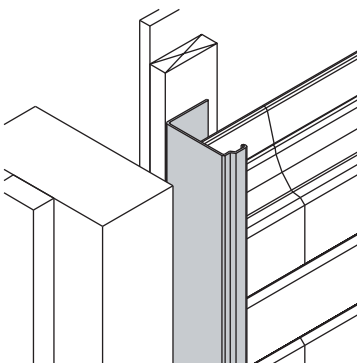
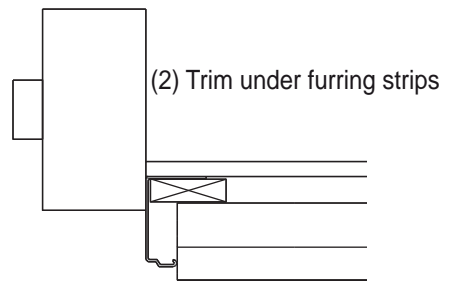
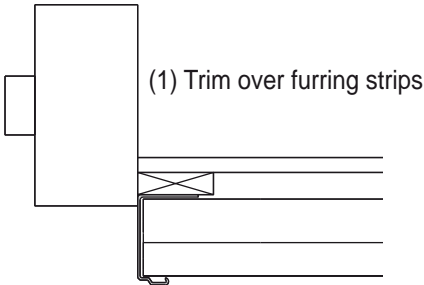
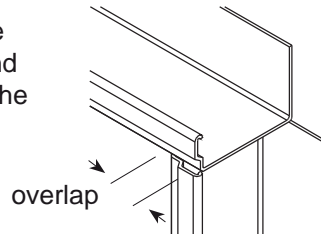
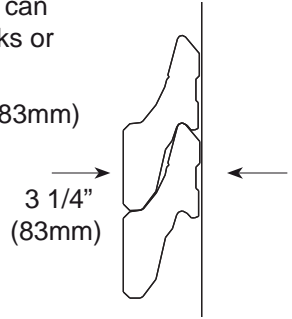

- Fasten the trim in place using small galvanized nails.
- Once the job is complete, apply caulking between the trim and the window frame, and in the second case also between the trim and the edge of Novabrik.

Aluminum or Steel Flashing Around Openings

Aluminum or steel flashing can also be used to extend the window frame out to give a clean, finished edge.

There are different ways to cap the sides of openings. Two common ways are shown below. Unless you own a metal brake, you will have to find a place to get your flashing bent. Take your measurements and make a drawing of what you need. Do not forget the flashing above openings.

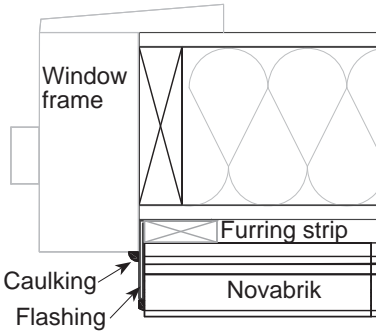

- Tack the aluminum piece in place.
- Fasten the furring strip over the metal flashing.

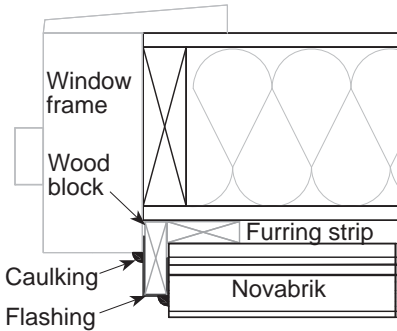

- Fasten wood block next to window frame.
- Fasten the furring strip next to wood block.
- Cover wood block with metal flashing.

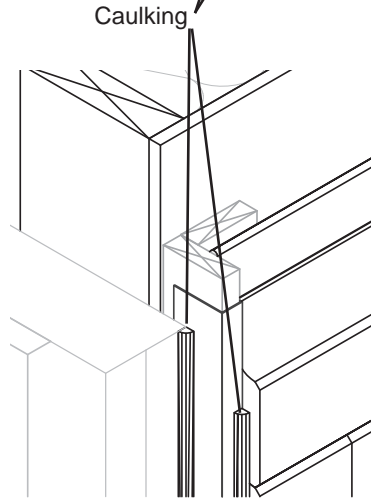
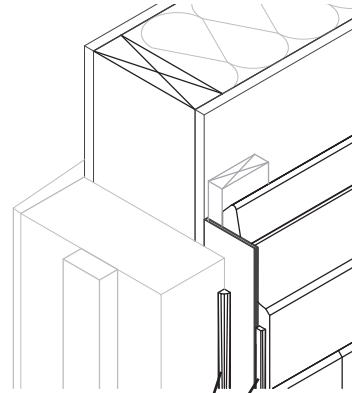

Remember to apply caulk along the window frame and the flashing, and the flashing and the brick.

Soldier Course Installation

A soldier course above windows and doors is pleasant to see and provides a perfect fit with above coursing.

- Fasten a 15" (380mm) high 3/4" (19mm) thick plywood over the opening.
- Install aluminum or steel flashing above opening (have it bent to size).
- Cover plywood and metallic flashing with a waterproof membrane or a housewrap.

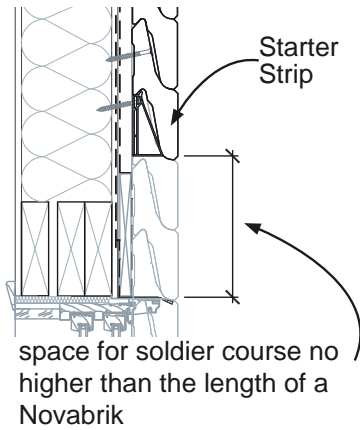
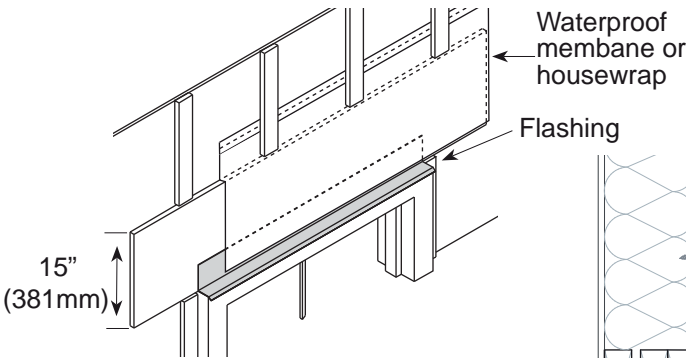
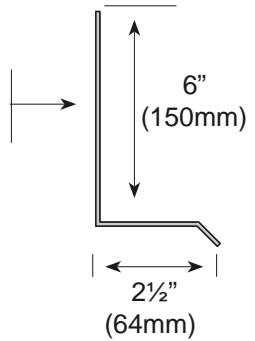

- Keep stacking Novabrik around the window or door.
- Leave a space above no higher than the length of one Novabrik.
- Attach starter strip to bridge the brick course above the soldier course opening.
- Install Novabrik with a #10 x 2 1/2" corrosion resistant screws per brick resting on the starter strip.
- At this point, you can complete the installation to the top of the wall and come back later to complete the soldier course.
- Cut to length and install soldier course in opening with two corrosion-resistant screws per brick.

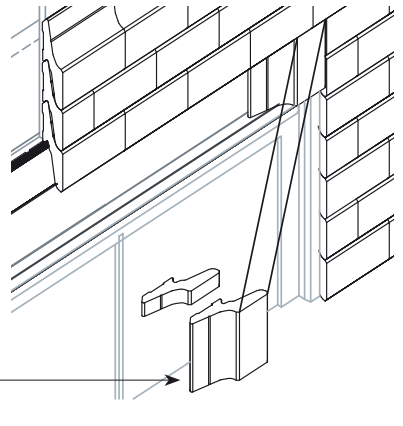

Soldier Course Installation

- Install the rest of the soldiers in the same manner.
- Remove the top part of the last Novabrik soldier and glue it in place.

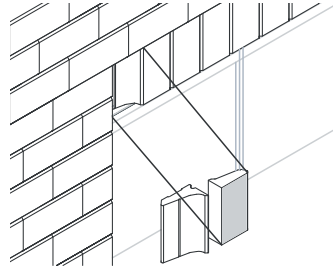
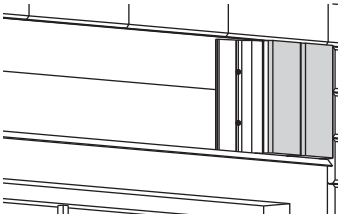

Note: If you need to cut a brick to fit the width of the opening, start installing soldiers at both ends and cut the brick in the middle of the opening. This will give a more symmetrical look.

Soldier Course Band

A different color soldier course looks good on high and long walls.

5. Install starter strip above soldier course and fasten each brick with one screw. Continue up the wall fastening bricks at each furring strip at every fourth course.

4. Fasten each soldier with two #10 2½" (64mm) corrosion resistant screws.

3. Cut brick and glue in place.

2. Fasten every brick of this course with two screws.

1. Fasten 18" (450mm) high plywood to studs and cover with flashing or house wrap.

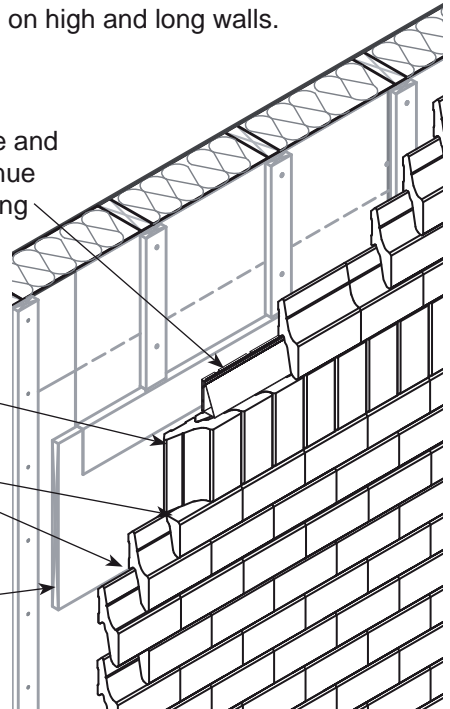

Installation on Rounded Openings

Installing Novabrik over round head windows or doors can be done in two ways. A horizontal course or a soldier course forming an arch. Arches can only be achieved over openings with a large radius.

In both cases, flashing around the opening is very important. Good quality materials and attention to details are critical.

Horizontal Coursing

- Fasten a 3/4" (19mm) thick plywood header over the opening (size according to the header chart).
- Install aluminum flashing around opening.
- Cover plywood and flashing with a waterproof membrane.
- Cut Novabrik using a grinder with a 4" (100mm) masonry blade to follow the contour of the opening.
- Apply sealant between the window frame and aluminum flashing.

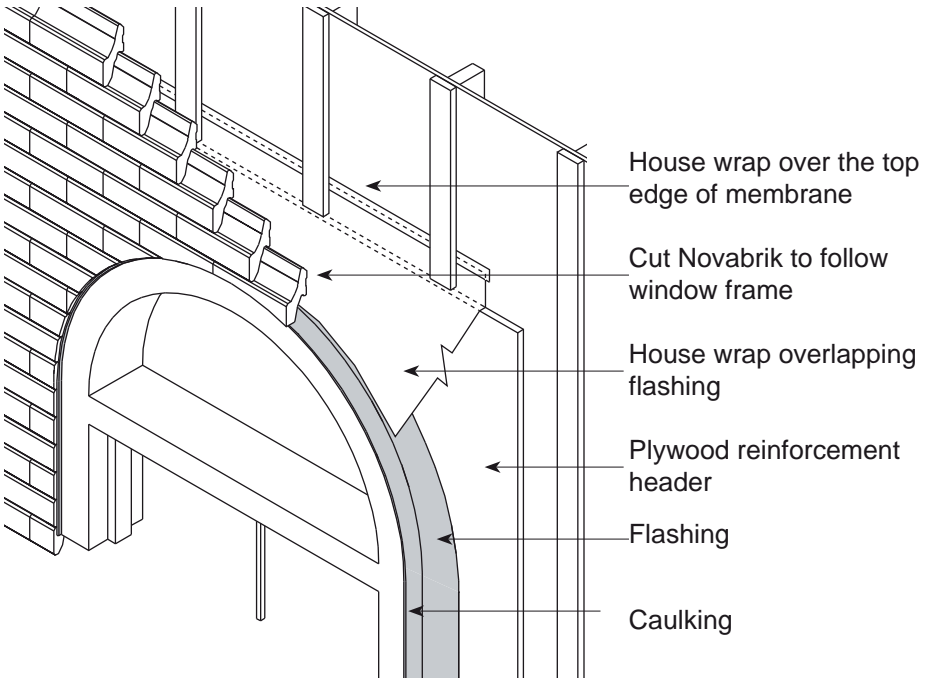
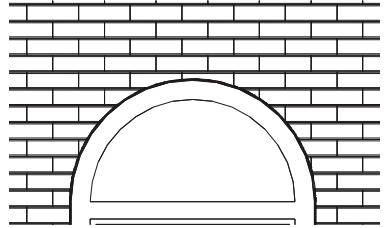

Installation on Rounded Openings

Making an Arch

Arches are done by opening the joint between two bricks at one end. The width of the gap is limited by aesthetics. This is why arches are limited to openings with a large radius.

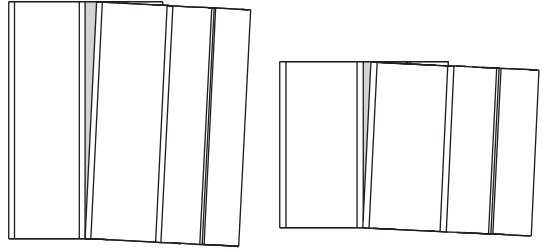

Reducing the height of the brick will allow for a shorter radius.

- Prepare the opening as shown on the previous page, with a plywood reinforcement header, housewrap and a waterproof membrane covering the plywood and aluminum flashing.
- Start from each end, fastening each brick with 2 screws and applying a large bead of butyl based sealant between the bricks.

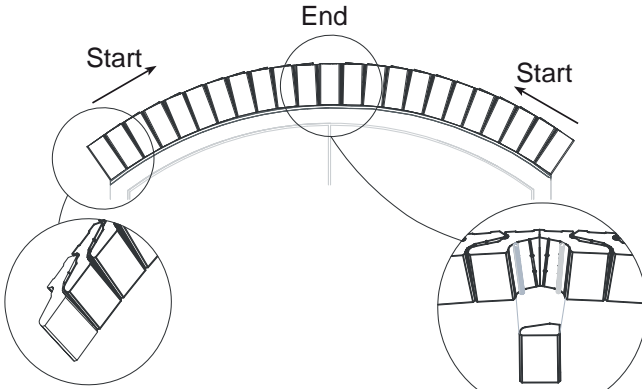

- For the last brick, cut the top part and secure with construction adhesive.

Sealing the arch

Apply a large bead of sealant between the bricks before you set them in place with two screws per brick. This will prevent water penetration.

Remember to install flashing over the opening and cover with housewrap or a waterproof membrane.

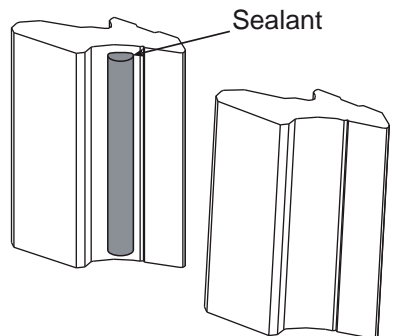

Soffit Details

This section shows the two most common ways to install Novabrik at the top of the wall. Best results will be achieved by running Novabrik up into the open eave and installing a new soffit.

On gable ends, install a new soffit against the Novabrik wall or use a shadow box.

New Soffit

- Install Novabrik up beyond the soffit line.
- Cut the bricks to fit under the roof trusses if necessary.

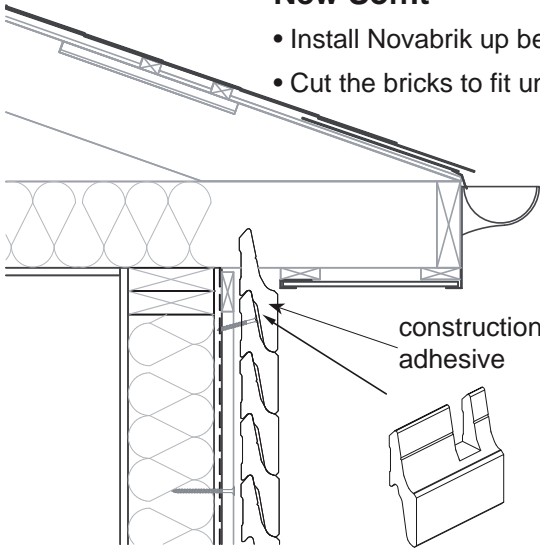

- Secure the second course from the top with corrosion-resistant screws.
- Set the last course in place with construction adhesive.
- Install new soffit, resting the j-trim against the Novabrik face.
- On gable ends, you may need to cut the top of the bricks at an angle.

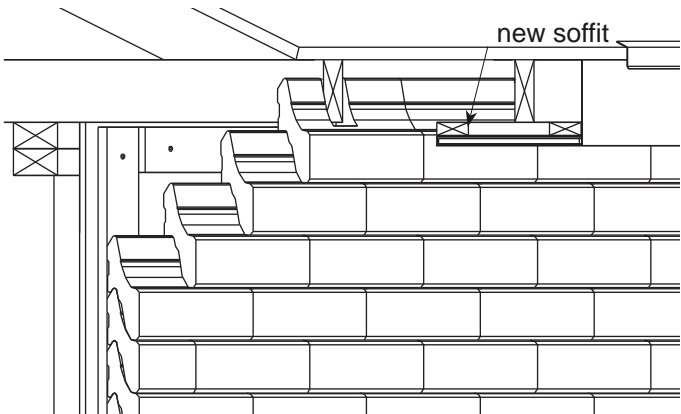

Soffit Details

Existing Soffit

- Install full bricks as high as possible.
- Cut the top of the brick to fit under the existing soffit.
- Insert a filler piece and attach with construction adhesive.
- You can also install a soldier course up to the soffit.

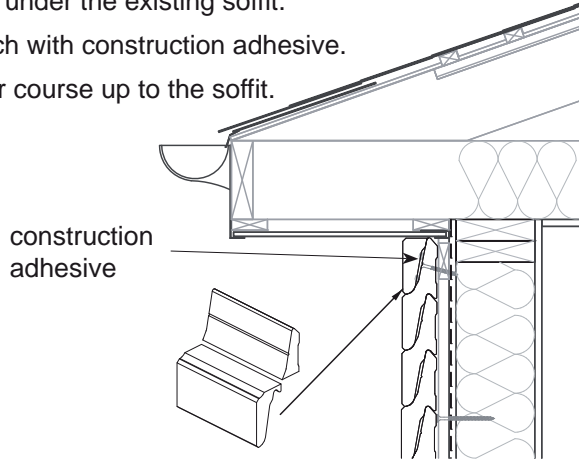

Wainscot Architectural Detail

Wainscoting is a very popular style. By combining Novabrik with any other siding material you can achieve a very appealing architectural style. For this we recommend the use of a story board to help determine the desired height of the wainscot cap.

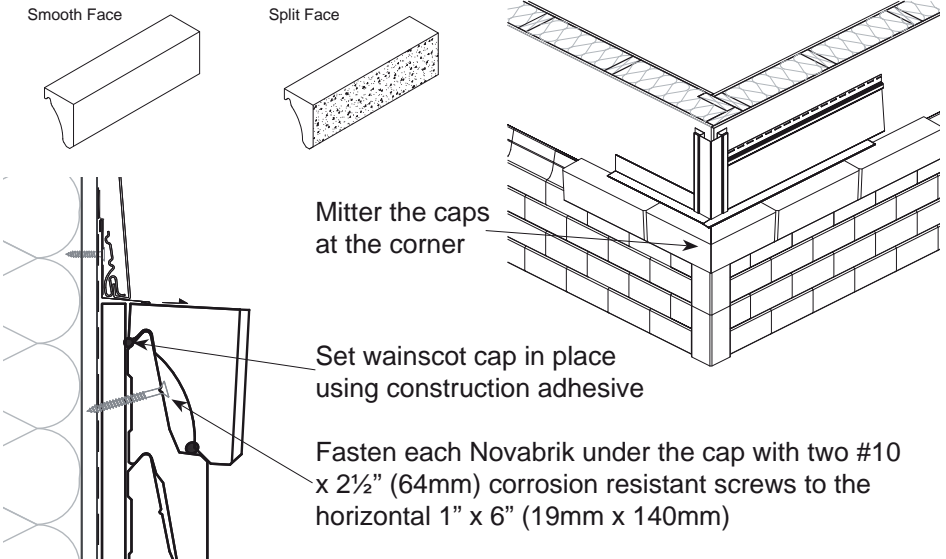

Novabrik on Various Types of Structures

Novabrik can be installed virtually anywhere. The following pages will show you additional examples of the versatility of this innovative brick veneer.

Novabrik on concrete blocks

The installation of Novabrik is done just like on a wooden structure. It is a simple procedure, therefore follow all the steps from the beginning of this guide. The key to a sound installation is to use concrete screws that have a secure grip into the concrete. **Consult a professional engineer for structure requirements.**

Without Insulation

- Install furring strips vertically at 16" (400mm) c/c on the wall with 3/16" (5mm) Ø concrete screws at 10" (250mm) c/c. The screws must penetrate at least 1 1/4" (32mm) into the structure.
- If necessary use shims behind furring strips to plumb the wall.
- Fasten Starter Strip with 3/16" (5mm) Ø concrete screws at 10" (250mm) c/c.
- Fasten first row of bricks into furring strips with #10 x 2 1/2" (64mm) corrosion resistant wood screws.
- Secure the Novabrik with #10 x 2 1/2" (64mm) corrosion resistant wood screws at every fourth course to each furring strip.

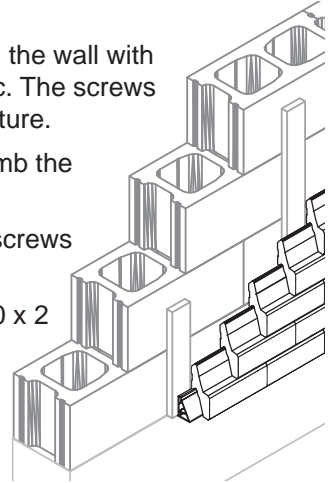

With Insulation

- Install furring strips vertically at 16" (400mm) c/c on the wall with 3/16" (5mm) Ø concrete screws at 10" (250mm) c/c. The screws must penetrate at least 1 1/4" (32mm) into the structure.
- Fasten starter strip with 3/16" (5mm) Ø concrete screws at 10" (250mm) c/c.
- Secure the Novabrik with # 10 x 2 1/2" (64mm) corrosion resistant wood screws at every fourth course to each furring strip.

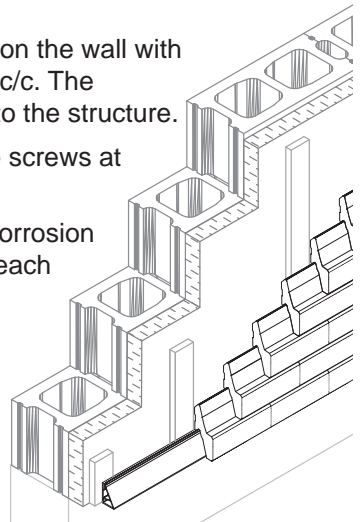

Note: Limit the insulation thickness to a maximum of 2" (50mm) when using Novabrik.

Novabrik on Various Types of Structures

Novabrik on Insulated Concrete Forms (ICF)

Before starting an ICF project, **consult a professional engineer for structural requirements.**

- Install 1" x 6" (19mm x 140mm) treated wood or furring strips covered with a waterproof membrane on the corners. Fasten with 3/16" (5mm) corrosion resistant concrete screws, with a minimum penetration into the concrete of 1 1/4" (32mm), at 10" (250mm) c.c. and 2" (50mm) from the inside edge of the form. Stagger the screws from one furring strip to the other, preferably by fastening 5" (127mm) higher then the other side.
- Fasten both corner planks together with #8 x 1 1/2 (38mm) corrosion resistant screws at 16"(400mm).
- Install furring strips vertically at 16" (400mm) c.c. on the wall with 3/16" (5mm) corrosion resistant concrete screws at 10" (250mm) c.c. with a minimum penetration of 1 1/4" (32mm) into the concrete.
- Fasten Starter Strip with 3/16" (5mm) concrete corrosion resistant screws with a minimum penetration of 1 1/4" (32mm) into the concrete.
- Secure the Novabrik with # 10 x 2 1/2" (64mm) corrosion resistant screws at every fourth course to each furring strip.
- Install the corner blocks according to the corner installation section of this installation guide.

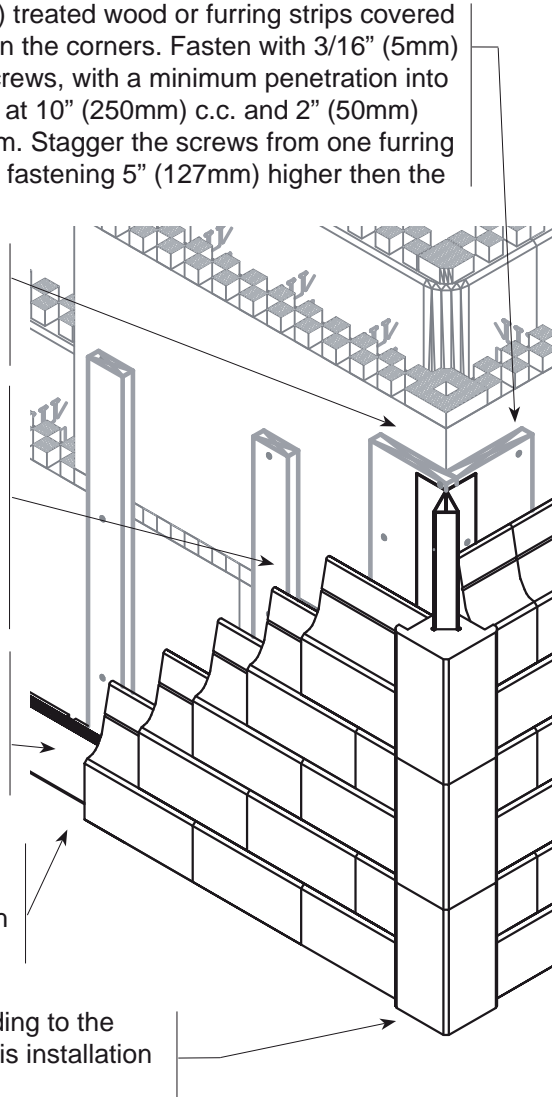

Note: Limit the insulation thickness to a maximum of 2" (50mm) when using Novabrik.

Novabrik on Various Types of Structures

Novabrik on Structural Insulated Panels (SIPs)

Before starting an SIPs project, **consult a professional engineer for structural requirements.**

- Install 1" x 3" (19mm x 64mm) treated wood or furring strips and fasten with #8 x 1½" (38mm) corrosion resistant concrete screws at 10" (250mm) c.c.

- Secure the Novabrik with # 10 x 2½" (64mm) corrosion resistant screws at every fourth course to each furring strip.

Sill plate

- Fasten the starter strip with #10 x 2½" (64mm) corrosion resistant screws into sill plate or perimeter joist at every furring strip. The screws must penetrate at least 1 1/4" (32mm) into the perimeter joists or into the studs.

Novabrik on Various Types of Structures

Novabrik on Post Frame structures

Post-frame buildings are sometimes called post-and-beam buildings. The design concept is simple and offers flexibility, which makes it a popular construction structure for agricultural and commercial applications.

- **Consult a professional engineer to review and approve your structure and design before you install Novabrik.**
- Refer to the beginning of this guide for Novabrik installation.

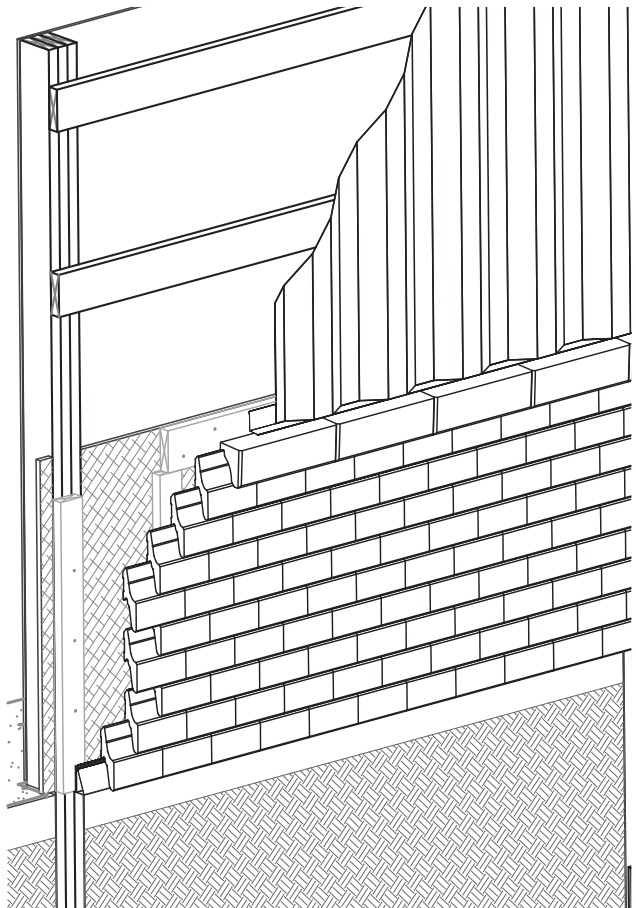

Note: Make sure framing is adequate to support the added weight of Novabrik.

Frequently Asked Questions

- **Will I ever need to paint it?**

The color is permanent and will not fade or peel like paint.

- **How long will Novabrik last?**

Like other high-strength concrete products, our Novabrik is made to last and is warranted for 50 years.

- **Where can I use Novabrik?**

Novabrik is great for all types of siding and remodeling projects. Since you won't need a brick ledge or mortar, Novabrik can be used on new or existing buildings both inside and outside.

- **Can Novabrik be used on concrete foundation walls?**

Yes. Just install pressure treated furring strips with concrete screws onto the concrete foundation walls. Follow recommended installation procedures.

- **Can I install Novabrik myself?**

Yes. If you are comfortable working with a few basic tools - masonry saw, hammer drill, level, and screw gun - you can install Novabrik. No special skills are required.

- **Should I use furring strips?**

We strongly recommend the use of furring strips. Furring strips create an air gap between the sheathing and the exterior siding. This cavity increases the drying capacity of any water that may have passed the cladding, thus reducing mold growth or structural deterioration.

- **Where do I place the strips?**

The furring strips are attached to the wall frame with corrosion-resistant screws. Attach the furring strips, 1/2" above desired level, to the existing frame, sill plate or perimeter joist, install first screw 10" above bottom edge of furring strip. Screws must penetrate at least 1 1/4" (32mm) into the studs.

Preparation tips

- When using power equipment, follow safety procedures.
- Predrill all Novabrik Corners and all first row Novabrik that will be screwed into furring strips.
- To predrill holes in the Novabrik, lay the brick on a flat surface and drill with the drill bit at a 90° angle to the ground.

Correct

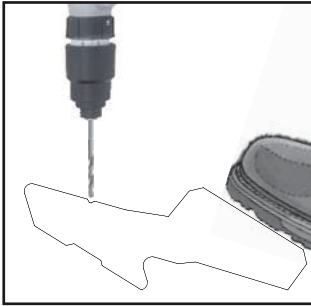

Incorrect

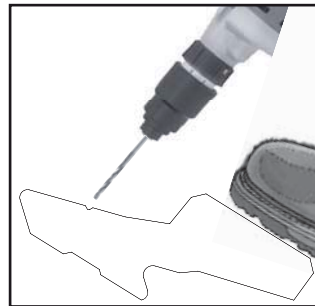

- After drilling holes or cutting the Novabrik, brush off any dust or concrete chips that may remain on the brick.
- Before installing the house wrap, mark down the location of the studs on the bottom horizontal furring strip to identify the position of the furring strips to install.

Installation tips

- If the screw does not penetrate the furring strip properly, it is probably because you have not hit the stud. Move the screw and reinstall.

More Tips

Installation tips

- Screw the furring strip 10" (250mm) from the bottom edge of the strip. The bottom will be screwed in once you install the Starter Strip.

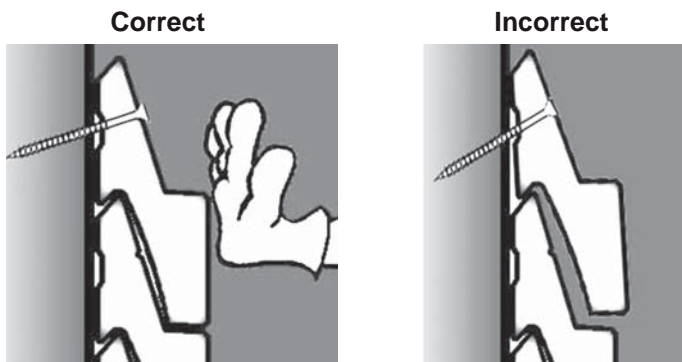

- Give a firm rubber hammer strike down on a 2" x 4" setting on the bricks, before fastening the bricks and tap the face of the bricks. This will set and level the brick before fastening.
- Hold down the face of the brick when fastening the Novabrik. This will prevent it from kicking out during this procedure.
- Cut and install the Novabrik in a way that the shiny side of the brick (the cut side) is less apparent. Do the same for window sills, i.e.: the cut side into the middle of the opening.

Tool tips

- A 14" blade will allow you to cut two bricks at once.
- Use two separate drills, one for screwing and the other for drilling into the masonry.
- Have a good pair of snips to cut the trims.

Stackable Brick System

Novabrik hangs on the wall

No bricks ledge is required

Can be installed on various

types of structures

Installation is as easy as...



1. Complete the prep work



2. Install the corner blocks



3. Fasten the bricks

Nova brik

SELF-VENTILATED MORTARLESS BRICK SIDING

Cindercrete Products, Ltd.

Head Office

Hwy #1 East
Regina, Saskatchewan, S4P 3A1

t: 306.789.2336
f: 306.789.7499

Distribution Yard

605 ave P South
Saskatoon, Saskatchewan, S7M 2W7

www.cindercrete.com

www.novabrik.com