

**DESIGN NOTES**

WET CAST	$f_c = 35 \text{ MPa (28d)}$
WET CAST AIR CONTENT	4 - 7 %
EXPOSURE CLASS	F-1
CEMENT	CSA A3001 (HS)
MESH (WWR)	ASTM A1064 (485 MPa)
REBAR	CSA G30.18 (400 MPa)
PRODUCT WEIGHT	4,660 kg
CONFORMANCE	CSA A257

**GENERAL NOTES:**  
 1) ALL UNITS IN mm UNLESS NOTED OTHERWISE

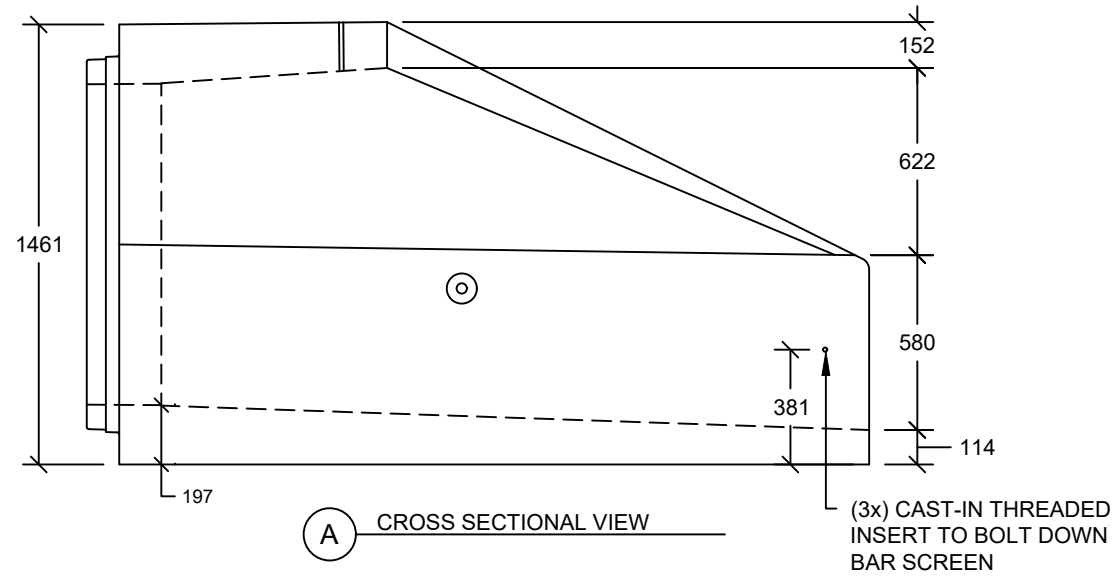
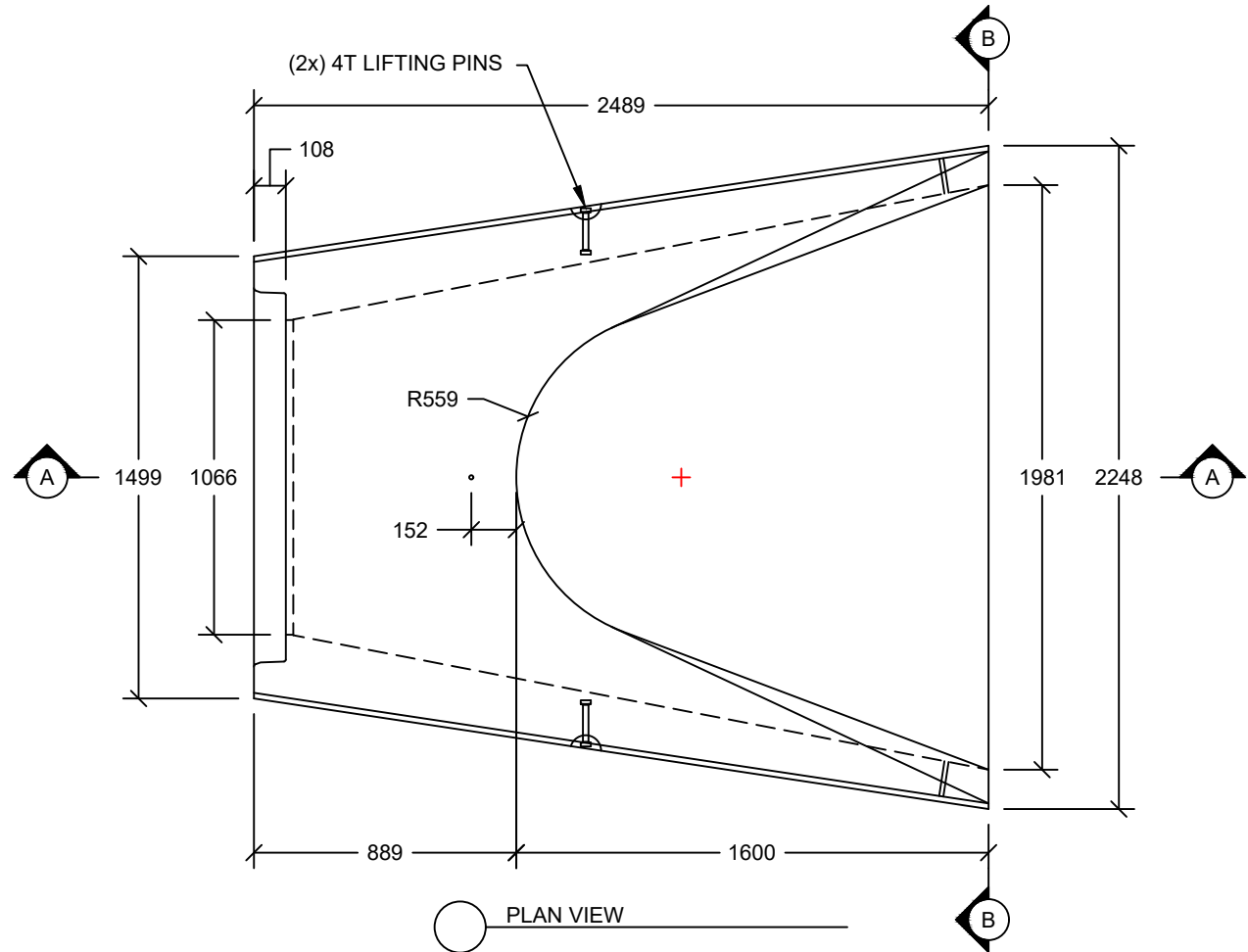

FLARED END AVAILABLE WITH EITHER BELL OR SPIGOT JOINT

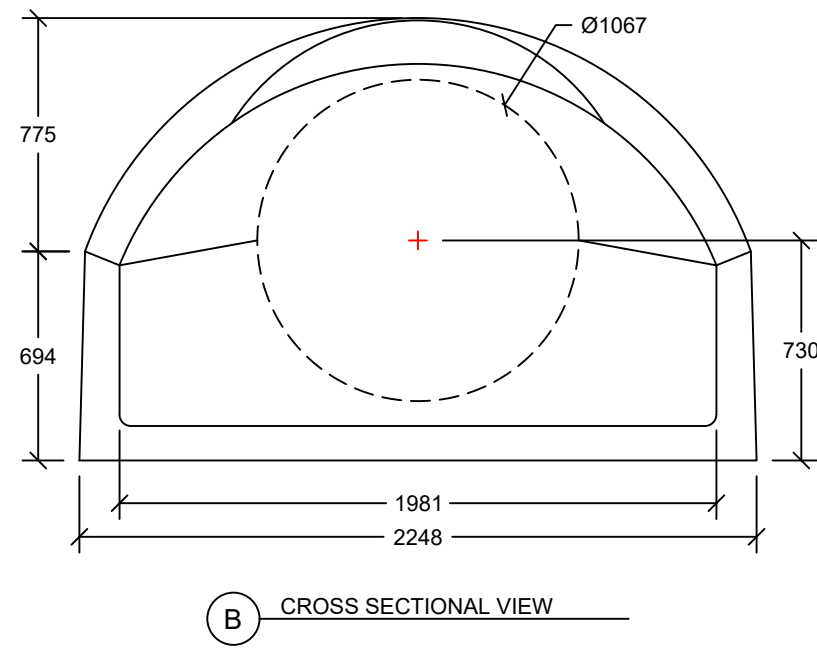

SHEET TITLE

Ø1050 FLARED END

PROJECT NAME

CONTRACTOR

DRAWN BY	DANIEL ROWE
CHECKED BY	K.M. -
JOB NUMBER	-----
REVISION	REV. 00
DATE	January 18, 2023

ISSUED FOR APPROVAL  
 ISSUED FOR CONSTRUCTION