

**DESIGN NOTES**

WET CAST	$f_c = 35 \text{ MPa (28d)}$
WET CAST AIR CONTENT	4 - 7 %
EXPOSURE CLASS	F-1
CEMENT	CSA A3001 (HS)
MESH (WWR)	ASTM A1064 (485 MPa)
REBAR	CSA G30.18 (400 MPa)
PRODUCT WEIGHT	3,665 kg
CONFORMANCE	CSA A257

**GENERAL NOTES:**  
 1) ALL UNITS IN mm UNLESS NOTED OTHERWISE

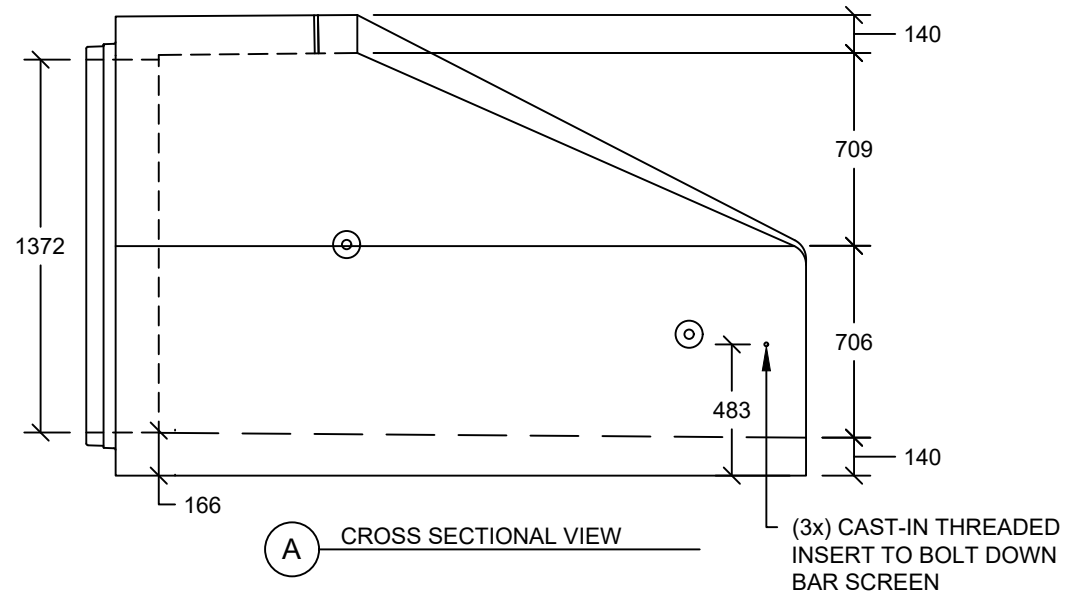
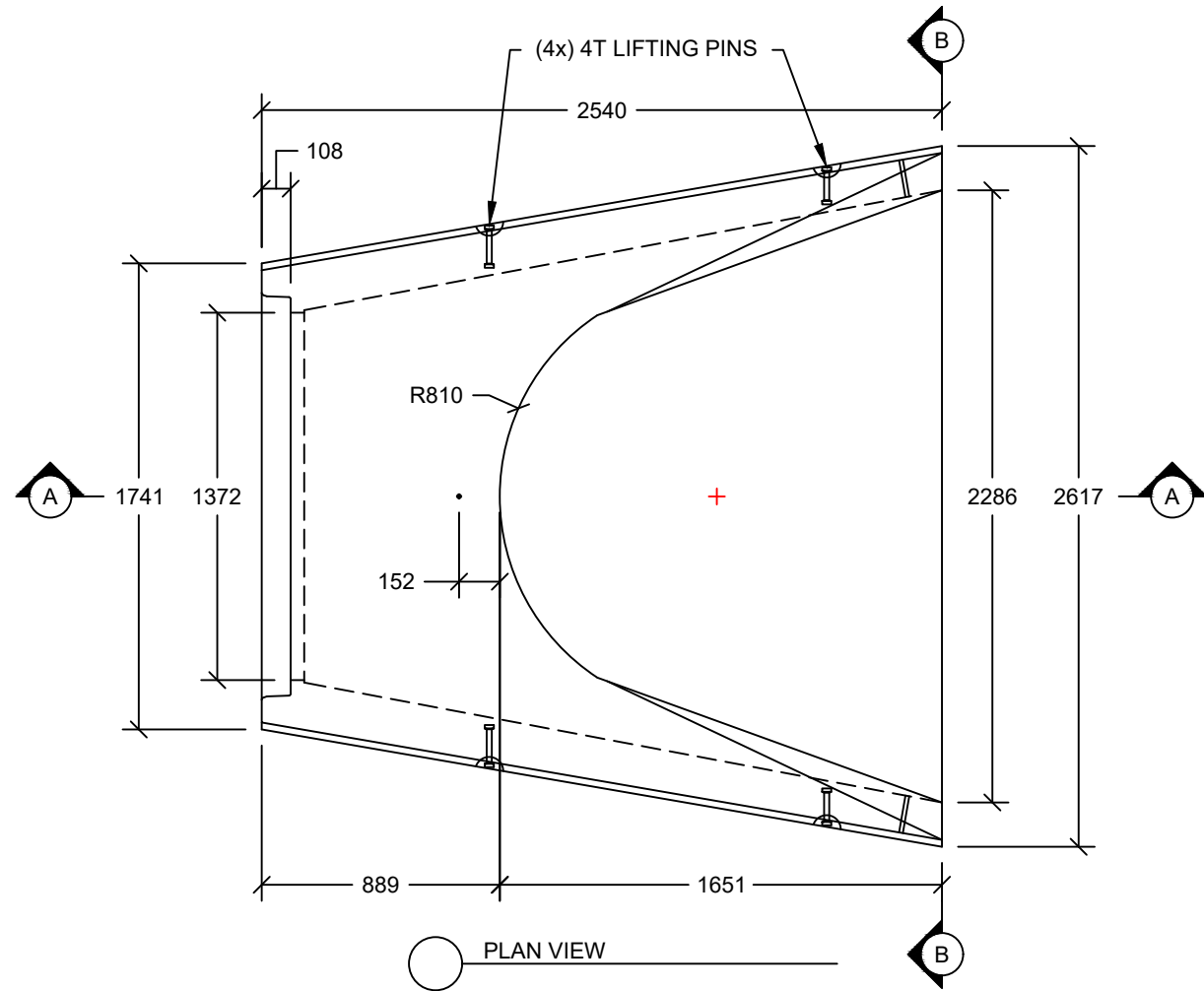

FLARED END AVAILABLE WITH EITHER BELL OR SPIGOT JOINT

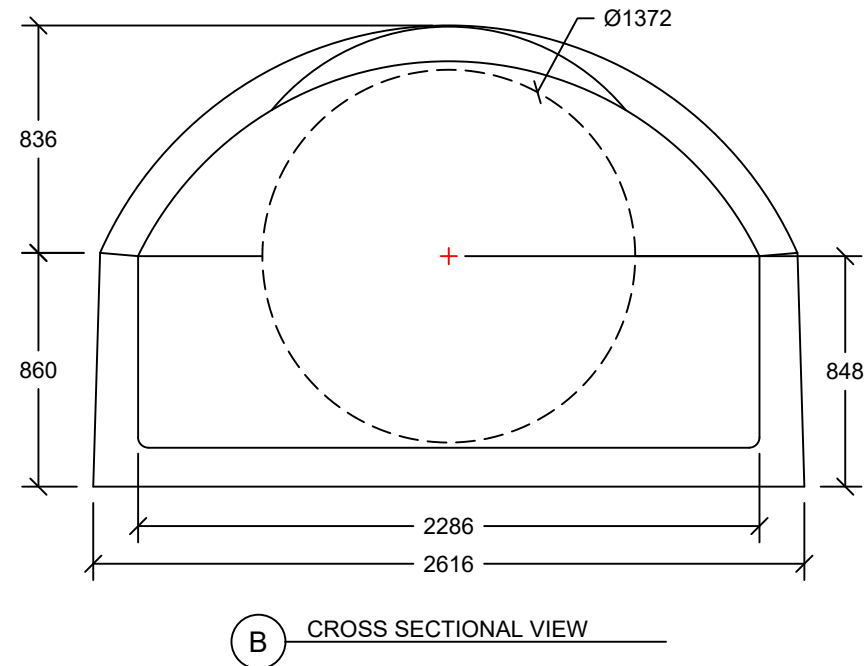

SHEET TITLE  
**Ø1350 FLARED END**

PROJECT NAME  
 -----

CONTRACTOR  
 -----

DRAWN BY	DANIEL ROWE
CHECKED BY	K.M. -
JOB NUMBER	-----
REVISION	REV. 00
DATE	January 18, 2023

ISSUED FOR APPROVAL  
 ISSUED FOR CONSTRUCTION