

DESIGN NOTES

DRY CAST	$f_c = 41.4 \text{ MPa (28d)}$
WET CAST	$f_c = 35 \text{ MPa (28d)}$
AIR ENTRAINMENT	N/A
EXPOSURE CLASS	N
CEMENT	CSA A3001 (GUL)
MESH (WWR)	ASTM A1064 (485 MPa)
REBAR	CSA G30.18 (400 MPa)
LIVE LOAD	NONE
TRAFFIC DIRECTION	ANY
SOIL DENSITY	21 kN/m^3
PRODUCT WEIGHT	$\sim 3,700 \text{ kg}$
CLEAR COVER	25 mm
CONFORMANCE	CSA A23.4

- GENERAL NOTES:**
- 1) ALL UNITS IN mm UNLESS NOTED OTHERWISE
 - 2) BENCHING TO BE DONE ON SITE BY OTHERS
 - 3) CB LEADS TO BE CORED ON SITE BY OTHERS UNLESS NOTED OTHERWISE
 - 4) ALL INTERNAL COMPONENTS TO BE SUPPLIED AND INSTALLED ON SITE BY OTHERS UNLESS NOTED OTHERWISE

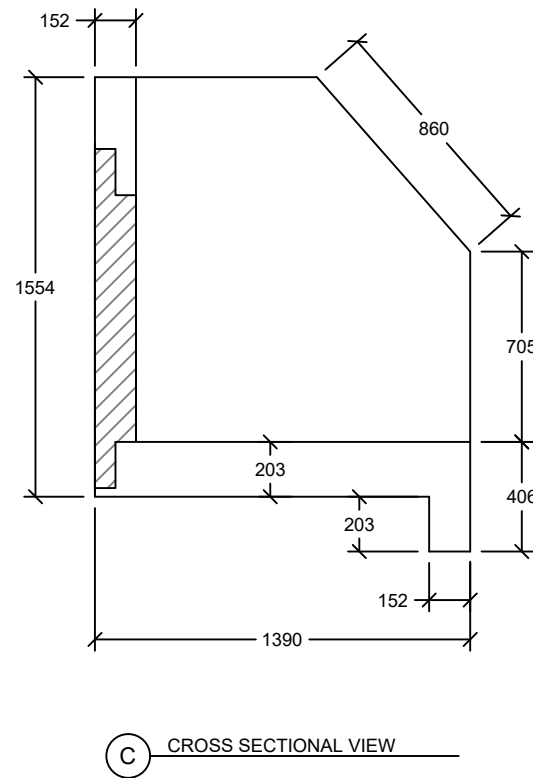
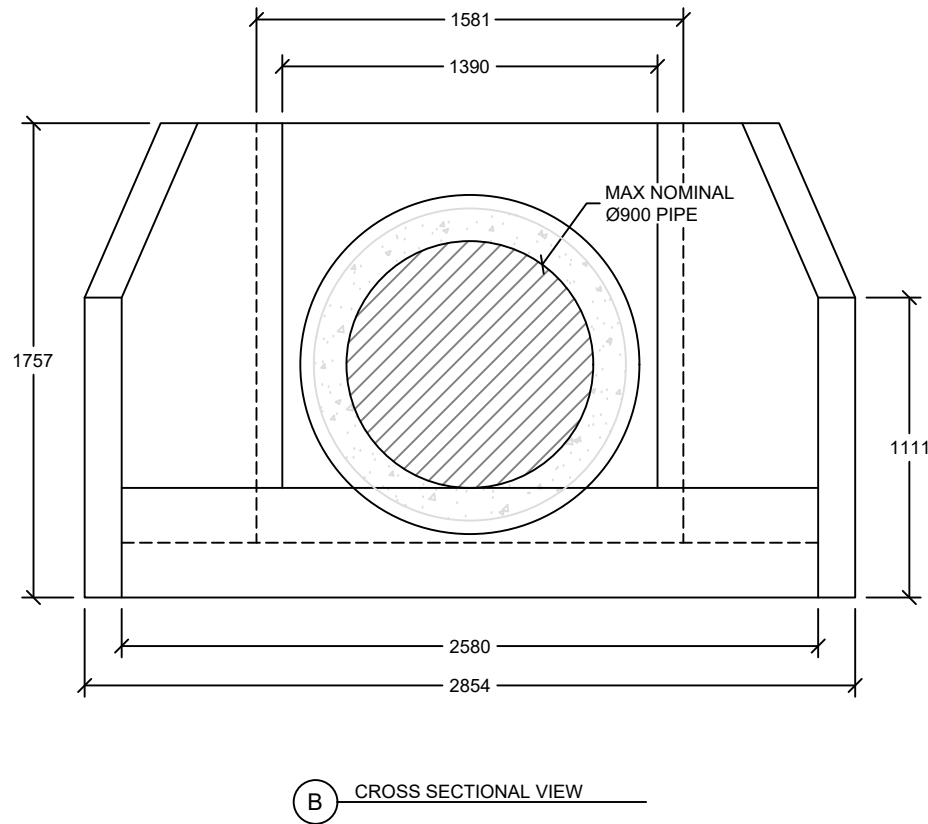
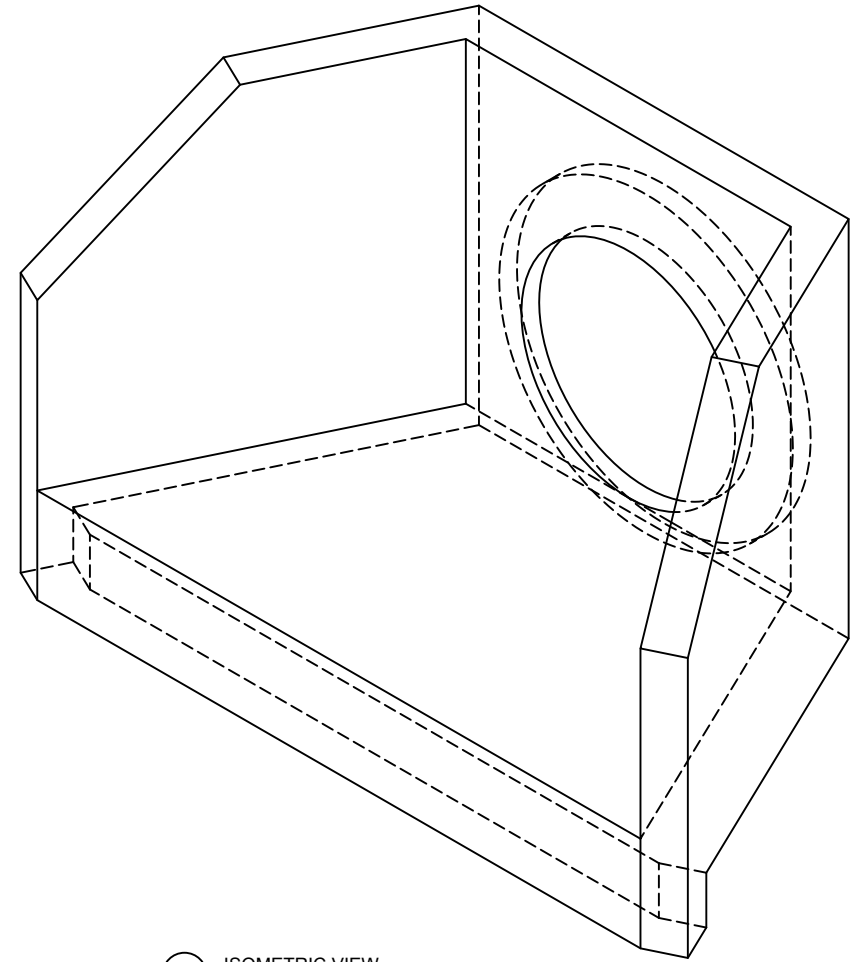
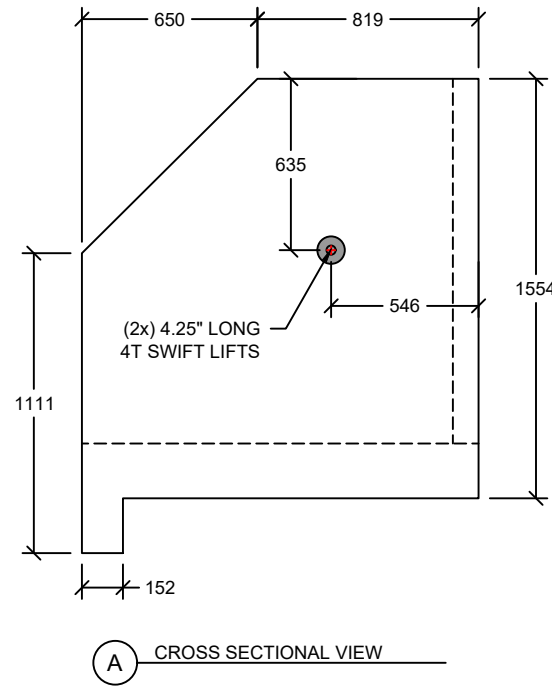
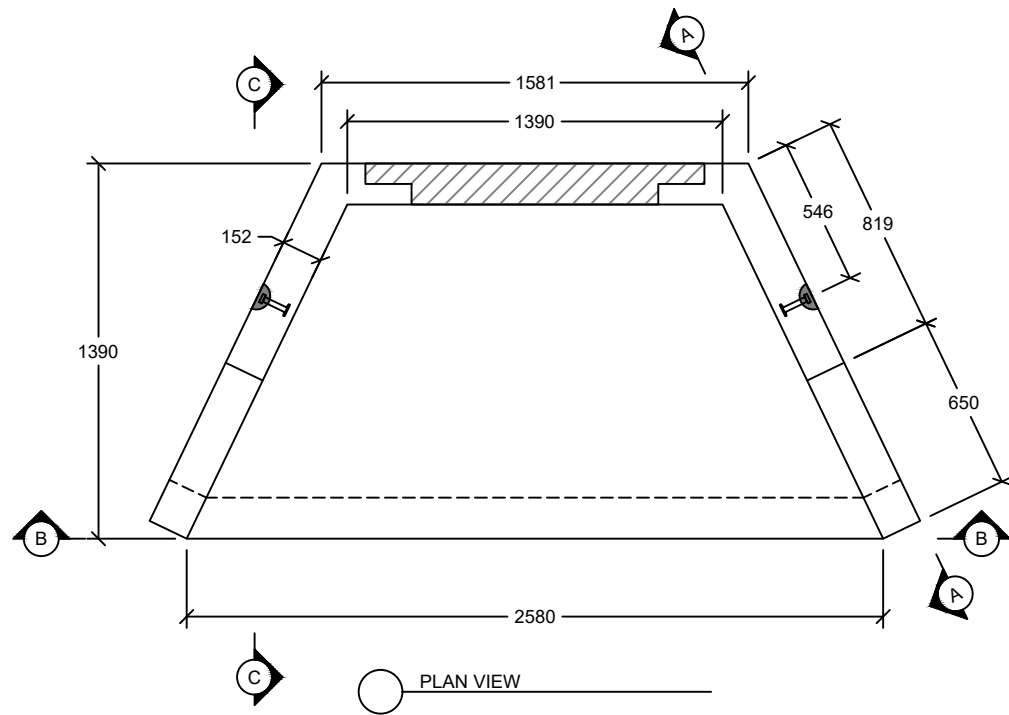

SHEET TITLE
**TYPE 14-15 HW
MAX. NOMINAL Ø900 PIPE**

PROJECT NAME

CONTRACTOR

DRAWN BY	KARI MORRISON
CHECKED BY	D.R. -
JOB NUMBER	-----
REVISION	REV. 00
DATE	January 26, 2024

- ISSUED FOR APPROVAL
- ISSUED FOR CONSTRUCTION