

DESIGN NOTES

WET CAST	$f_c = 35 \text{ MPa (28d)}$
WET CAST AIR CONTENT	4 - 7 %
EXPOSURE CLASS	F-1
CEMENT	CSA A3001 (HS)
MESH (WWR)	ASTM A1064 (485 MPa)
REBAR	CSA G30.18 (400 MPa)
PRODUCT WEIGHT	1,010 kg
CONFORMANCE	CSA A257

GENERAL NOTES:
 1) ALL UNITS IN mm UNLESS NOTED OTHERWISE

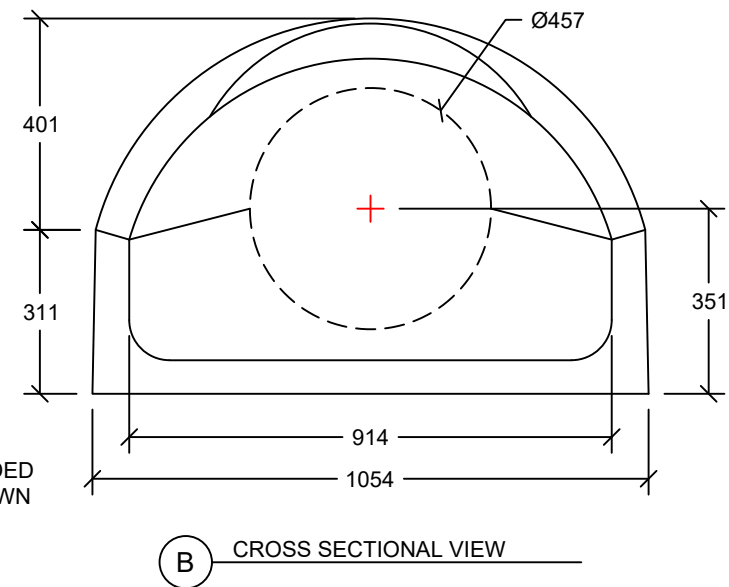
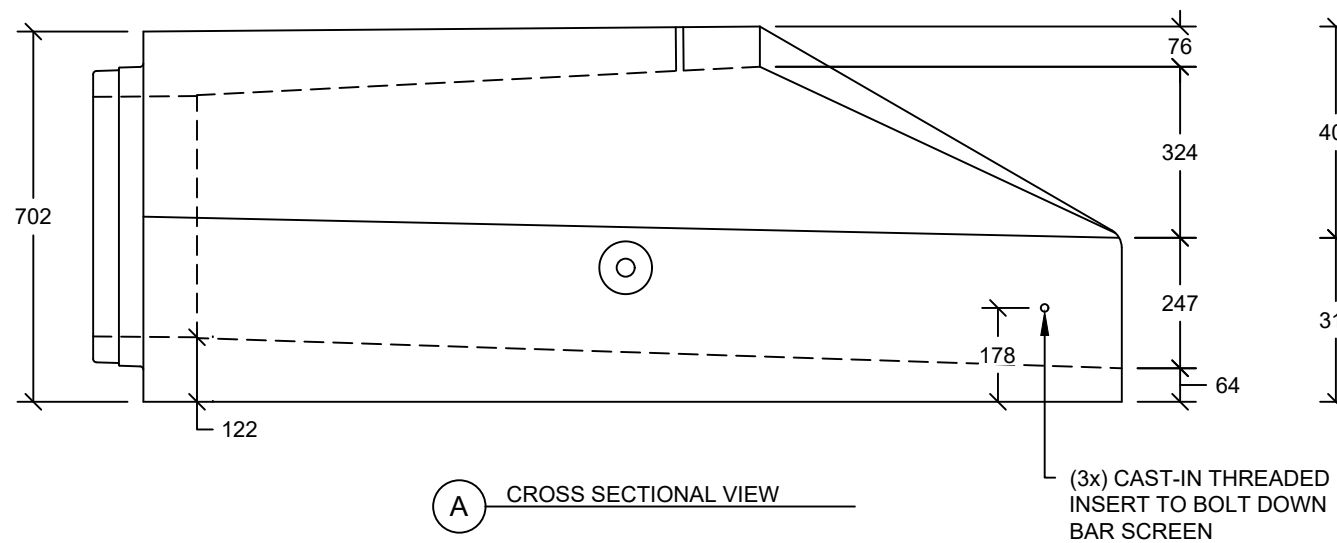
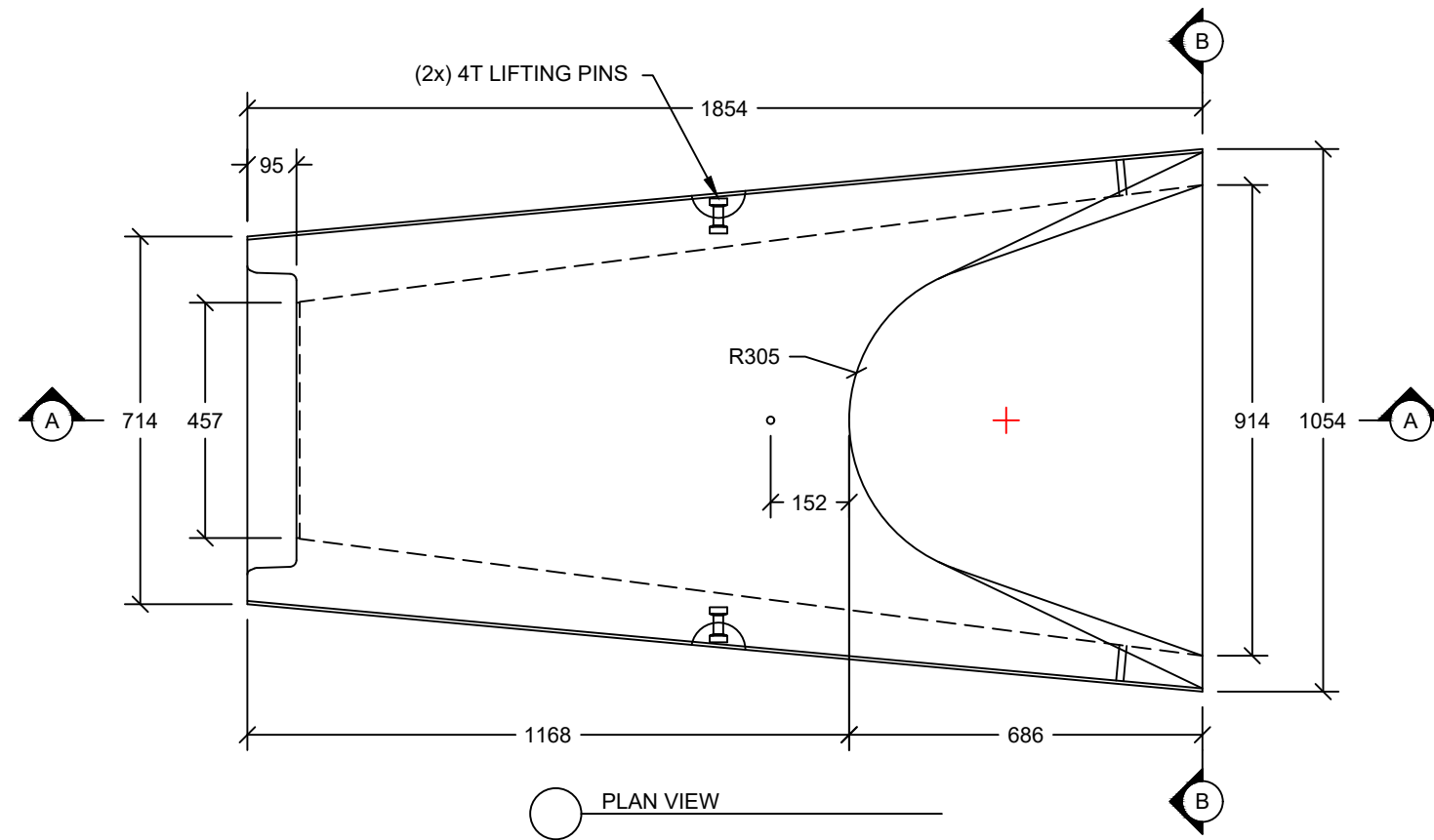

FLARED END AVAILABLE WITH EITHER BELL OR SPIGOT JOINT



SHEET TITLE	
Ø450 FLARED END	
PROJECT NAME	

CONTRACTOR	

DRAWN BY	DANIEL ROWE
CHECKED BY	K.M. -
JOB NUMBER	-----
REVISION	REV. 00
DATE	January 18, 2023

ISSUED FOR APPROVAL
 ISSUED FOR CONSTRUCTION