

CAP

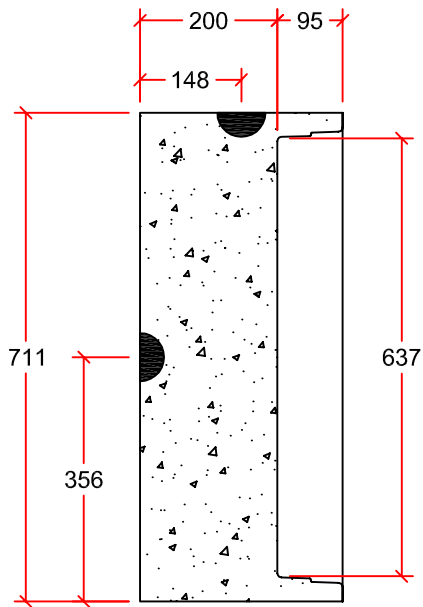

PROFILE VIEW

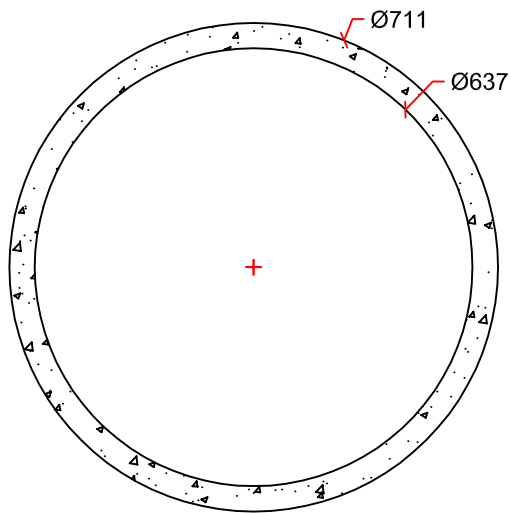

SECTION DETAIL

PLUG

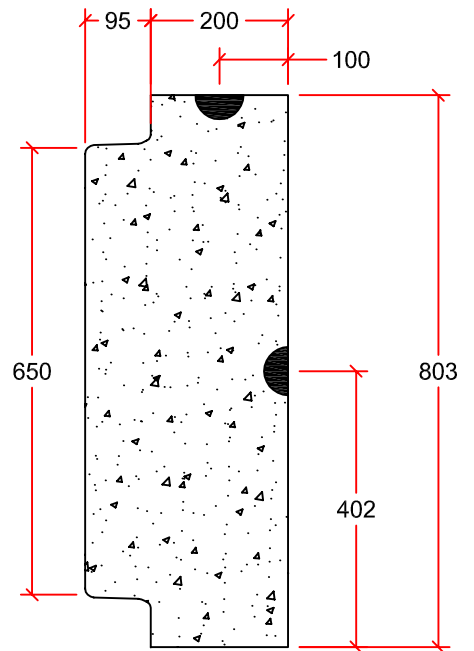

PROFILE VIEW

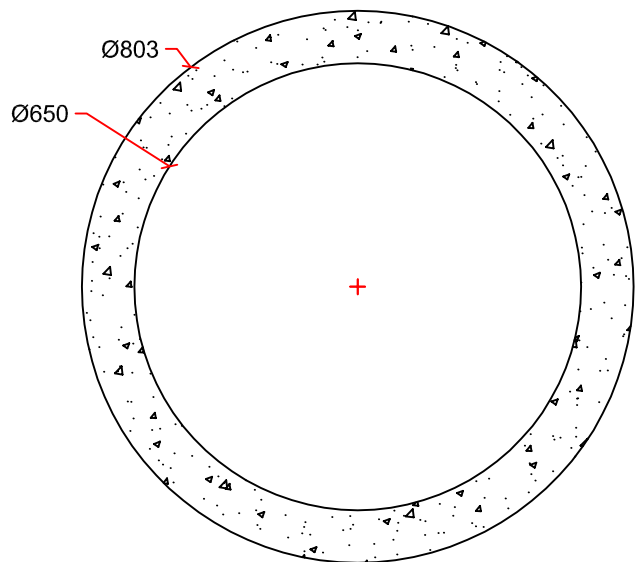

SECTION DETAIL

ADAPTORS

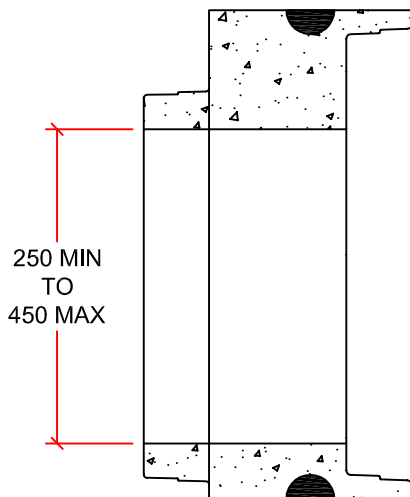

DECREASER

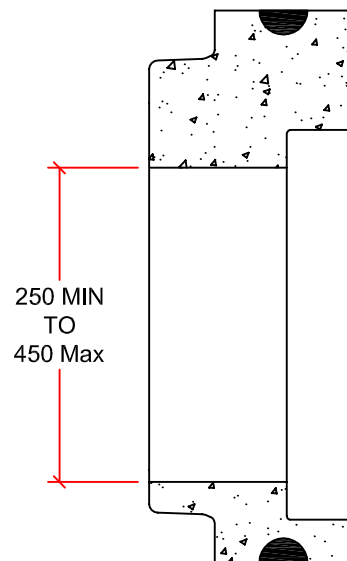

INCREASER

DRAWN BY:	LUCAS STEFAN	Ø525mm PCA (NAB)	<b>INLAND</b> Pipe 7336 112th AVE. NW. CALGARY, AB. PH: 403 279-5531 FAX: 403 279-7648
SCALE:	NTS		
DATE:	NOVEMBER 16, 2015	(2) 4T SWIFT LIFTS ON EACH APPROX. MASS: CAP:209 kg PLUG:320 kg DIMENSIONS IN mm	
DRAWING #:	Ø525 PCA (NAB)		
REVISION #:	REV. 1		
CHECKED BY:	TYSON DYCK		