

1050mm SLAB TOP
W/ 635mm OPENING

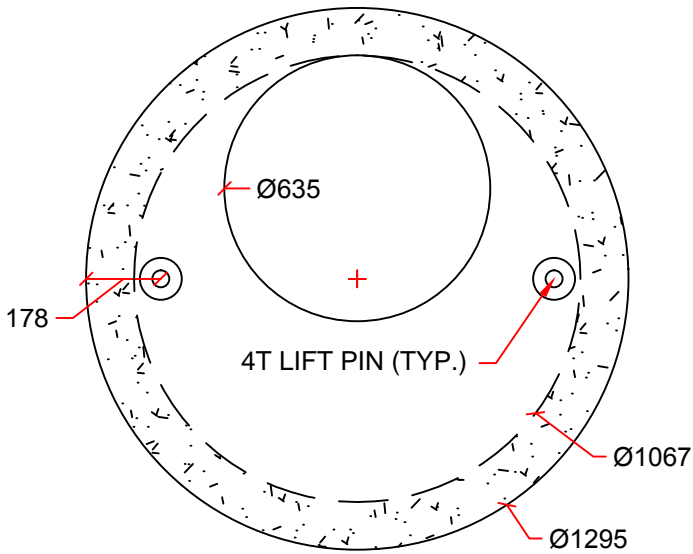

PLAN VIEW

1050mm/635mm x 0.92m
CONICAL TOP

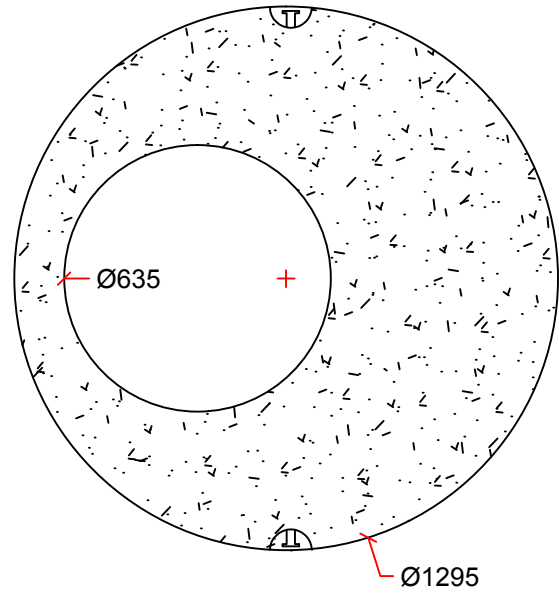

PLAN VIEW

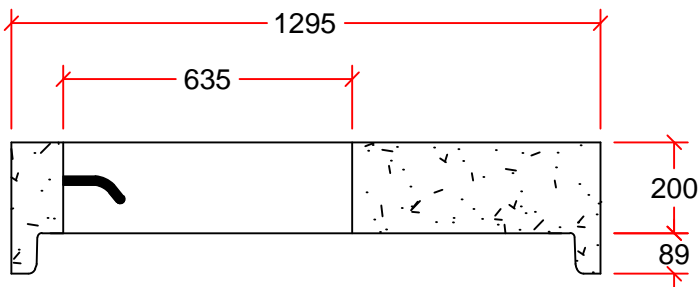

SIDE VIEW

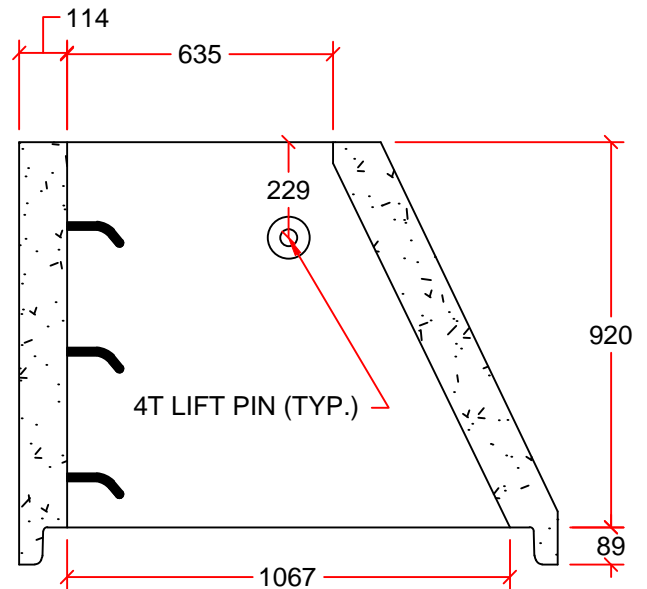

SIDE VIEW

DRAWN BY:	SAM HAN
SCALE:	NTS
DATE:	NOVEMBER 18, 2015
DRAWING #:	1050mm SLAB TOP
REVISION #:	REV. 1
CHECKED BY:	TYSON DYCK

1050mm/635mm MANHOLE SLAB TOP
DIMENSIONS IN mm

INLAND
Pipe

3000 10th AVE. REGINA, SK.
PH: 204 334-4300 FAX: 204 334-7957