

SIDE VIEW

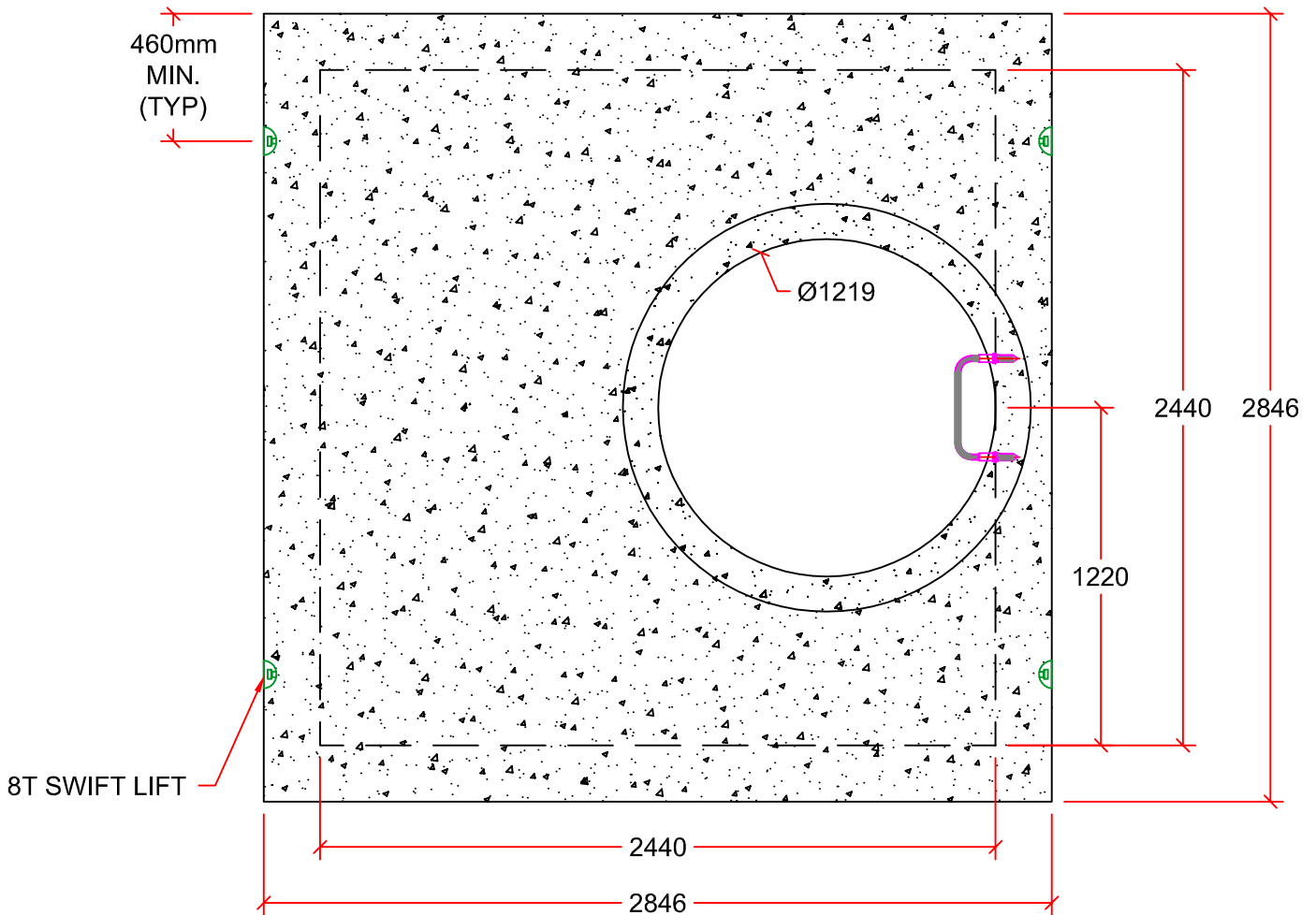

TOP VIEW

DRAWN BY:	LUCAS STEFAN	2440x2440 VAULT TOP	
SCALE:	NTS		
DATE:	NOVEMBER 3, 2015	DIMENSIONS IN mm 710mm OPENINGS AVAILABLE	
DRAWING #:	2440x2440 VAULT TOP		
REVISION #:	REV. 1		
CHECKED BY:	TYSON DYCK		
7336 112th AVE. NW. CALGARY, AB. PH: 403 279-5531 FAX: 403 279-7648			