

MAXIMUM PIPE SIZE FOR STRAIGHT THROUGH INSTALLATION

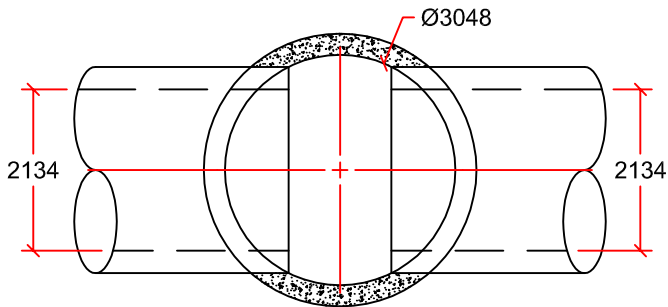

MAXIMUM PIPE SIZE FOR RIGHT ANGLE INSTALLATION

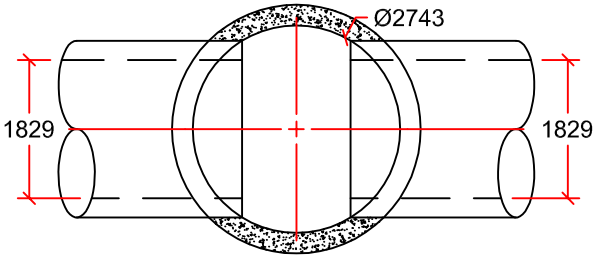
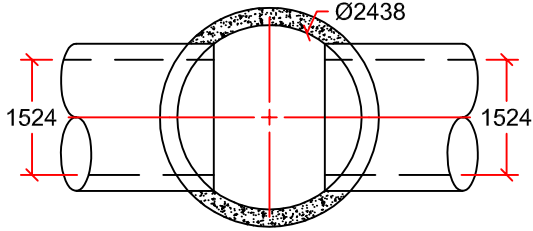
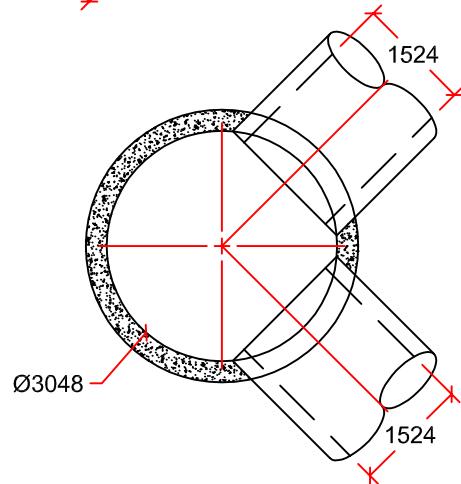
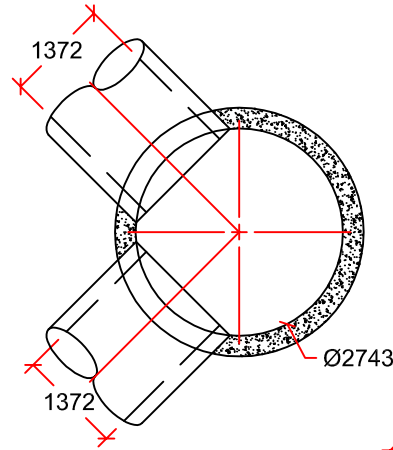
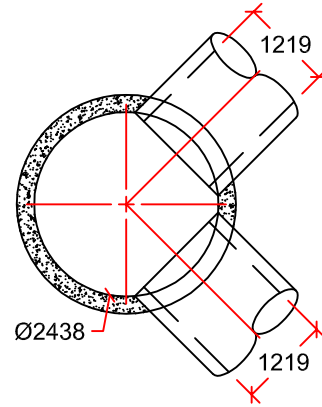

DRAWN BY:	AARON KLEMETS	MAXIMUM PIPE SIZES FOR MANHOLES  2400MM THROUGH 3050MM MANHOLES  NON-STANDARD ANGLES POSSIBLE, CALL FOR SPECIFIC PROJECT SITUATIONS
SCALE:	NTS	
DATE:	NOVEMBER 12, 2015	
DRAWING #:	MAX MH 2400-3050	
REVISION #:	REV. 0	
CHECKED BY:	TYSON DYCK	



9265 OAK ST. VANCOUVER B.C.  
PH: 604 269-6700 FAX: 604 261-6751